

AUTO PILOT SYSTEM

SAS-70

Instruction Manual



CONTENTS

Chapter 1. Preview	5
1.1 About SAS-70	5
1.2 Possible interference to Electronic Compass from outside	5
1.3 Accuracy on Plotter mode.....	5
1.4 Characteristics of SAS-70.....	5
Chapter 2. Brief Manual for SAS-70.....	6
2.1 Manual Steering	7
2.2 Compass Steering	7
2.3 Plotter Steering	7
2.4 Remote Steering.....	7
2.5 Dial Steering	7
2.6 Wave Height Ratio set.....	8
2.7 Rudder Angle Ratio set	8
2.8 Deviation Correction	8
2.9 Product Specification.....	8
Chapter 3. Cautions with handling.....	9
3.1 Cautions while using	9
3.2 Cautions while installation.....	9
3.1.1 Installation for display unit of SAS-70	9
3.1.2 Installation for direction sensor	9
3.1.3 Installation for Solenoid valve.....	9
3.1.4 Installation for Transmitter.....	10
3.1.5 Hydraulic piping	10
3.1.6 Electric Wiring.....	10
Chapter 4. How to operate	11
4.1 Function of front panel button for a display unit.....	11
4.2 Configuration of Menu.....	12
4.2.1 Menu.....	12
4.2.2 Set for adjust ratio	12
4.3 Screen of Display unit.....	13
4.4 MANUAL STEERING (HAND)	14
4.5 COMPASS STEERING	14
4.6 PLOTTER STEERING	15
4.7 REMOTE STEERING	15
4.8 DIAL STEERING	15
4.9 AVOIDANCE / ROTATION	16
4.10 TYPES OF SCREENS FOR OTHER NAVIGATION INFORMATION.....	16
4.11 ADJUSTMENT OF VARIATION	17
4.12 ADJUSTMENT OF WAVE HEIGHT RATIO	17
4.13 ADJUSTMENT OF RUDDER ANGLE RATIO.....	18

4.14 ADJUSTMENT OF SCREEN BRIGHTNESS	18
4.15 FUNCTIONS OF REMOTE CONTROLLER	19
4.15.1 Remote Controller of RC-10A.....	19
Chapter 5. System Installation.....	20
5.1 BEFORE INSTALLATION.....	20
5.2 CONFIGURATION OF SYSTEM	20
5.3 INSTALLATION FOR AUTO PILOT	20
5.3.1 Installation for display units.....	20
5.3.2 Installation for Compass sensor (Electronic Compass).....	21
5.3.3. Installation for Solenoid valve.....	21
5.3.4 Installation for Transmitter.....	22
Chapter 6. Hydraulic Piping	23
6.1 Before Hydraulic piping.....	23
6.2 Piping diagram before installation for Solenoid valve.....	23
6.3 Piping diagram after installation for Solenoid valve.....	24
6.4 Piping diagram at a cylinder type.....	25
Chapter 7. Electric Diagram	27
7.1 Before hydraulic piping	27
7.2 Interference to Radio equipment	27
7.3 Cautions in initial Power-On.....	27
Chapter 8. Initial Setup after installation	28
8.1 Initial setup	28
8.1.1 Power ON/OFF	28
8.1.2 Rudder setup	29
8.1.3 Remote setup.....	31
8.1.4 Compass adjustment.....	32
8.1.5 System setup.....	34
8.1.6 Option, Warning, Measurement.....	35
8.1.7 Self test result.....	35
8.1.8 Adjustment for Solenoid valve	36
8.2 Self Test	37
Chapter 9. Funtions of Alert and Trouble indicator	38
9.1 Alert Function.....	38
9.2 Remote Alert Funtion for adjustment	38
9.3 Funtion for indicating troubles (Operate Error)	38
SM-975A ELECTRONIC LEVER.....	39
INSTRUCTION MANUAL	39
Chapter 1. Preview	39
1.1 Engine Control (SM-975A)	39
1.2 Product Specification.....	39

1.3 Cautions for operation	39
1.4 Terms and abbreviation.....	40
1.4.1 Terms Explanation.....	40
1.4.2 Abbreviation Explanation	40
Chapter 2. System Installation.....	41
2.1 Installation of Control Cables.....	41
2.2 How to connect Control cables	42
2.3 Cable connection to manual lever.....	43
2.4 Wiring Connection.....	44
2.5 Drawing for wiring connection (Connected to Auto Pilot).....	45
2.6 Drawing for wiring connection (Electronic lever separate type).....	46
2.7 Cautions in initial power-on	46
Chapter 3. Initial setup after installation.....	47
3.1 Controller for initial setup	47
3.2 Operating setup (Setup + Power ON).....	48
3.3 Functional setup (Setup + Select + Power ON)	51
3.4 Default values for operation / functions	52
Chapter 4. How to Operate.....	53
4.1 Functions for Remote Controller	53
4.2 How to operate for Remote Controller	53
Chapter 5. Drawing for SM-975A	55
5.1 Outline drawing for Electronic Lever	55
5.2 Outline drawing for Remote Controller	55
5.3 System Configuration	56
5.3.1 Configuration for Electronic Lever separate type (SM-975A)	56
5.3.2 Auto Steering / Electronic Lever (SAS-70+SM-975A).....	56
5.4 Connecting diagram for Electronic lever.....	57
Chapter 6. PACKING LIST	58
6.1 SAS-70.....	58
6.2 SAS-70 OPTION(In case of additional SM-975A)	60
Chapter 7. PRODUCTS DRAWINGS	61
Chapter 8. Warranty.....	65
☞ Thank you for your purchasing of Auto Pilot manufactured by Samyung ENC.	
☞ Pay attention to navigation owing to there is no alert function for collision on this unit.	
☞ The specification might be changed for higher efficiency without any notice.	
☞ Please look into this manual before operation.	
☞ We propose you to turn off the power immediately if the units have wrong symptom.	
☞ Keep this manual beside on the units all the time.	

Chapter 1. Preview

1.1 About SAS-70

SAS-70 is an automatic marine navigation system that is developed by SAMYUNG ENC CO., LTD. and will make you ease to control the ship when it is mounted in small vessel with canalizing the whole information like ships location, ships direction, true speed, the route to navigate, the direction to navigate and the direction of magnetic north radar. It is automatically controlled to navigate at users discretion. SAS-70 will fully satisfy your demand.

SAS-70 is compact, light and easy to control. Considering for the internal power supply of ships, SAS-70 is available with DC 24Voltage, power supply for marine ships and the bearing variation is a very high accuracy as values of less than $\pm 2^\circ$. In case of connecting to various GPS plotters, it can be configured properly according to the ship conditions.

It is designed to control at a remote place by connecting to a remote controller during the navigation and the ships courses are monitored to a remote and the controller was designed as type of water resistance.

1.2 Possible interference to Electronic Compass from outside

SAS-70 Auto Pilot can detect the head-bearings by using electronic compass. The deviation of head bearings in a mode of compass might interfere automatic steering so that the accurate bearings are required. Accordingly, it should be installed according to the installation manual. If it is installed at a place, which can be effected by magnetic objects, the automatic steering cannot be worked.

In addition, when electronic wire is wired near at electronic compass sensor or objects as such a magnet, tools, nails, speakers are passing by the compass, the ships might sudden turn to left or right direction so that the materials should be at least more than 1 meter apart from the electronic compass.

1.3 Accuracy on Plotter mode

In plotter mode, the steering is controlled by GPS plotter signal that connected to SAS-7. Accordingly, the accuracy of plotter devices gives influence to the one of ships' location.

GPS accuracy of the devices is not the main stream. The ships can be always affected by wind, wave, tides etc. so that you should pay attention to the courses if the ships might be swerved from the courses, which is monitored on a Plotter mode. The band of deviation - It

Is up to setup of wave- height ratio, rudder angle ratio and marine weather condition - could be reached about from 20m to 40m. Considering these variables objects, pay attention to the courses could be deviated off more than 50m from your expected positions.

This is not 100% reliable device even though it is an auto steering unit receiving GPS signal.

In the meantime, you always need to pay attention to the navigation.

1.4 Characteristics of SAS-70

The characteristics of SAS-70 are as followings.

- ❖ Easy installation with a light-compact type
- ❖ Install at small spaces as separated display unit and control unit
- ❖ Designed to view all navigate information by using a 5.6inch LCD display
- ❖ Easy operation by using push / dial button

- ❖ Efficient numerous functions as such Night mode, Compass display, Data display, avoidance.

Chapter 2. Brief Manual for SAS-70

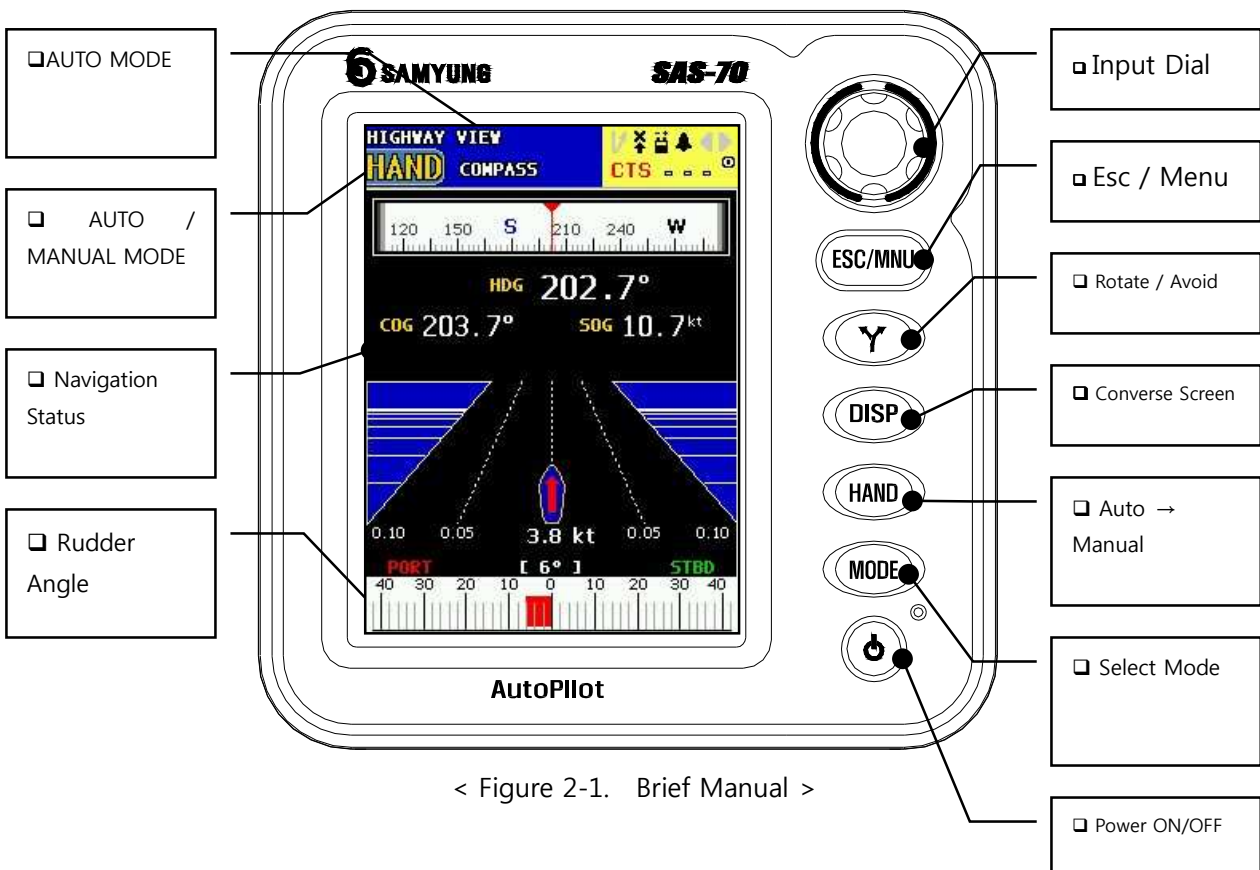
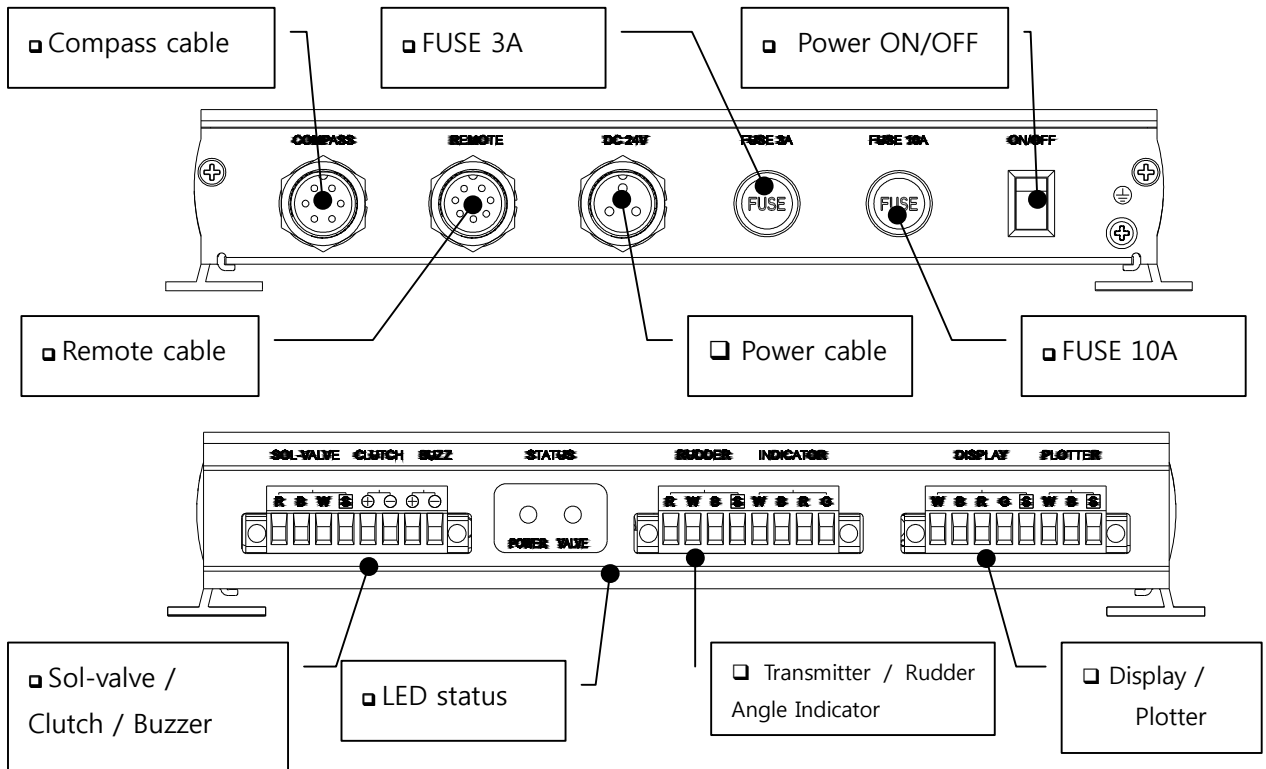

< Figure 2-1. Brief Manual >

2.1 Manual Steering

Auto mode converses to Manual mode if you press  button.

Recommend you Manual Steering mode in following environments.

- ❖ Area of tough wave or narrow waterway
- ❖ Harbors with lots of ships
- ❖ In case of short-visual area for heavy foggy

The current status as such head bearings as well as rudder angle indicator is indicated in the Manual Steering mode.

2.2 Compass Steering

Compass Steering is indicated in the Auto Steering mode.

Put Remote Controller onto a center and select Compass mode by pressing  button. Then, the current heading bearings will be setup to the waypoint bearings.

- ❖ According to adjustment of wave height ratio, the bearing errors might be occurred.
- ❖ Able to adjust ships as turning more than 5° from the center of the Remote controller.
- ❖ Able to adjust the required heading as dialing of the indicator.

2.3 Plotter Steering

Plotter Steering is indicated in the Auto Steering mode.

Put the Remote controller at a center and then, select the Plotter mode by pressing the front  button. The ships navigate to setting waypoints automatically.

- ❖ Navigates to the way of current bearings in case of no setup of waypoint in a Plotter.
- ❖ Able to adjust ships as turning more than 5° from the center of the Remote controller.

2.4 Remote Steering

Remote Steering is indicated in the Auto Steering mode.

Select the Remote mode by pressing the front  button. It is able to adjust ships as dialing of the Remote controller.

- ❖ Turn the Remote controller slowly.
- ❖ The heading bearings, Steering indicate, working bearings of solenoid and so on in the indicator.
- ❖ The heading bearings are indicated in a display of the Remote controller.

2.5 Dial Steering

Dial Steering is indicated in the Auto Steering mode.

Select the Dial mode by pressing the front  button. It is able to adjust ships as dialing of the front indicator.

- ❖ The current status of the rudder is indicated at a display when you turn the dial.
- ❖ The Remote controller is not operated in Dial Steering.

2.6 Wave Height Ratio set

The wave height ratio should be adjusted according to the height of wave.

Put "0" in low wave, "8" in high wave.

- ❖ Normally, Compass = 4, Plotter = 4.
- ❖ If the wave height ratio is setup too high, the heading bearings shakes to right and left by wave and the rudder is moving in vain by working of solenoid valve. In the meantime, the bearings errors are higher when the ship is arrived at waypoint in Compass Steering and the route errors are wider on navigation in Plotter Steering.

2.7 Rudder Angle Ratio set

Adjustment of Rudder Angle Ratio must be adequately setup in accordance with conditions such as size of ship, weight of ship, strength of wind, wave, current etc. and especially current is much more important impact.

Setup 0.1 in weak current and 3.0 in severe current.

- ❖ Setup 1.5 in common navigation. The Rudder Angle Ratio is operated when automatic Steering is done by Compass / Plotter.
- ❖ If the rudder angle ratio is setup too low, it is deviated from the waypoint bearings and if the rudder angle ratio is setup too high, the heading of ship shacks to right and left and in case of severe case, it can be navigated in zigzags.

2.8 Deviation Correction

The Deviation is corrected by Compass correction and you can correct it by turning a dial in case of delicate correction.

- ❖ The Deviation is corrected in proportion as values to be setup on Compass Deviation ratio. (Ref. 8.1.4 Compass Correction)
- ❖ Setup the values by turning [Dial], then save the values by pressing  button.

2.9 Product Specification

- ❖ POWER SUPPLY : DC 18 ~ 32 V (Recommend DC 24V)
- ❖ POWER CONSUMPTION: Less than 85W
- ❖ Range of Temperature : -15°C ~ +55°C
- ❖ SOLENOID : DC 24V, Max. 3A, Two times to right / left
- ❖ SIZE : Display horizon. (159mm) / verti. (158mm) / width (50mm)
Controller horizon. (233mm) / verti. (123mm) / width (41mm)
- ❖ Heading Angle Resolution : 0.5°
- ❖ L C D : 5.6 inch TFT Color LCD
- ❖ L C D Resolution : 960(W) X 234(H)
- ❖ Display mode : Highway, Compass, direction / velocity of wind, gauge, tank, data
- ❖ AUTO Steering mode : Compass, Plotter, Remote, Dial Steering mode
- ❖ Language : Korean, English

Chapter 3. Cautions with handling

3.1 Cautions while using

- ❖ If there happens thunder lightning, don't try to touch the metal part of the power switch. There is danger of electronic shock by lightning strikes.
- ❖ Only DC 24V power is available. If it is connected to AC power or not to standard power, it could cause a fire, an electronic shocks or breakdown of device.
- ❖ Use the standard fuse. If non-standardized fuse is used while replacement, it will cause fire and breakdown.
- ❖ Don't treat the cable forcefully and don't give a pressure on cable. Damaged cable could be a cause of a fire and electronic shock.
- ❖ Don't operate remote, compass and plotter function in case of bad range of vision like in the harbor tiny water-way, near at obstacles. Unexpected electronic trouble could cause a collision.
- ❖ Full attention required around ship and a course Unexpected trouble could cause a collision.
- ❖ In case of emergency, shift the operating switch to manual operating mode.
- ❖ Keep away from water, the steering controller and solenoid valve are not perfectly waterproof. So it could be cause of fire and electronic shock. When device gets wet, turn off power supply and input power switch. After that make a check.
- ❖ Don't turn on engine starter, after connecting power supply. It causes a rapid change of voltage and improper operation.
- ❖ Don't smash remote controller against floor or wall.

3.2 Cautions while installation

3.1.1 Installation for display unit of SAS-70

- ❖ Don't mount control amplifier at the place where could cause trouble to drive ship.
- ❖ Avoid high vibrating places, high temperature, sea water and rain.
- ❖ Avoid places to be affected by direct rays of the sun.
- ❖ Make it clear how to shift to manual operating mode against emergency mode.

3.1.2 Installation for direction sensor

- ❖ Check out if the direction sensor at least 1M away form magnetic objects (tools, speakers etc.).
- ❖ If magnetic objects are close, the ships might be twisted owing to change of the heading bearings' angle.
- ❖ Keep away magnetic classified tools from the device.

3.1.3 Installation for Solenoid valve

- ❖ Install it horizontally. Otherwise, it might be cause troubles.

3.1.4 Installation for Transmitter

- ❖ Avoid places at high vibration, high temperature, rain and sea-water.

3.1.5 Hydraulic piping

- ❖ After finishing piping work, clean pipe and around pipe and then disassemble linked part and do flushing.
- ❖ Dust and protrusion might be cause troubles.
- ❖ Only use pipe cutter for cutting and cut it in perpendicular with a cutter.
- ❖ After completely finished the hydraulic piping, clean the oil tank clearly and change oils.
- ❖ Put permanent magnet into an oil tank in order to eliminate steel leavings.

3.1.6 Electric Wiring

- ❖ Work on Power Off. Otherwise, it could cause a short circuit and breakdown.
- ❖ Connect cable to terminal of device in accordance with installation manual.
- ❖ Wrong connecting, it could cause breakdown.
- ❖ Firmly fasten screws and connectors.
- ❖ Keep away possibly from radio equipment (SSB, VHF etc.).
- ❖ Keep away cables of Auto Pilot from ones of Radio equipment because it might be interfered by Radio equipment in accordance with the location of installation.

Chapter 4. How to operate

4.1 Function of front panel button for a display unit

Describe names, function of front panel.

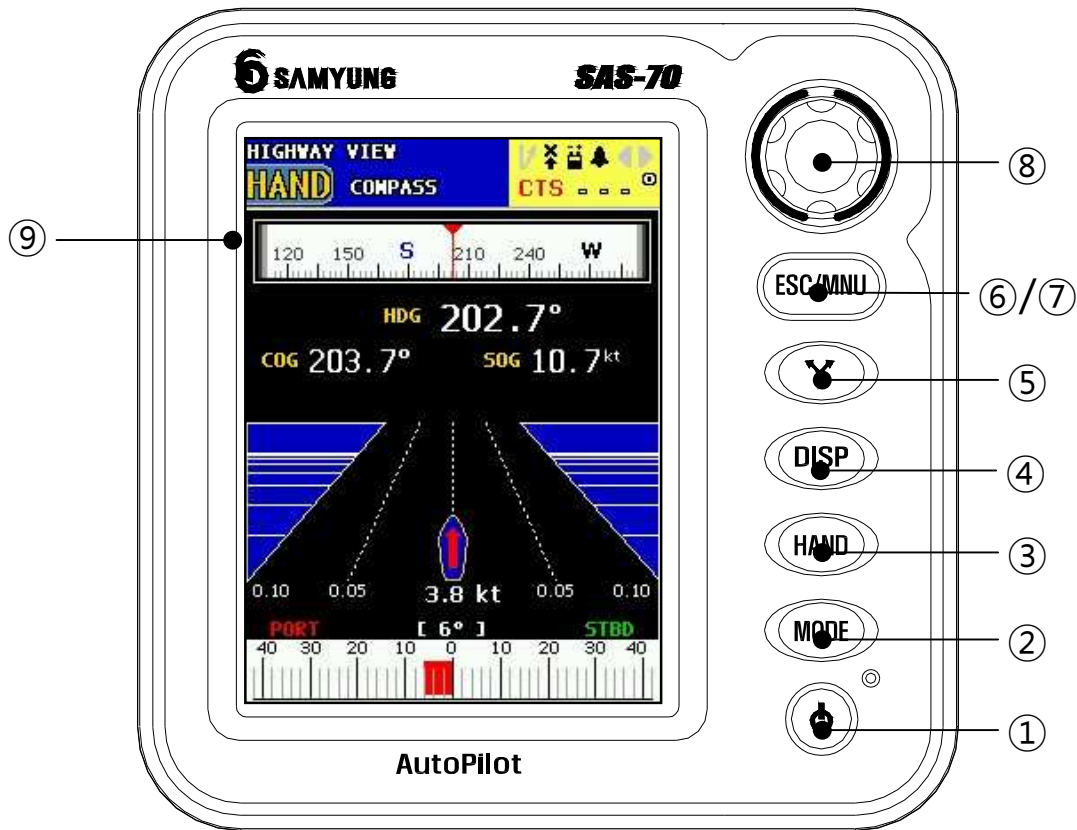

< Figure 4-1 Front panel of SAS-70 >

NO	Name	Button	Function
①	POWER		Power ON/OFF (Press power button for 2 sec. To turn OFF)
②	MODE		Select Compass, Plotter, Remote, Dial
③	MANUAL		Changed to Manual mode
④	SCREEN		Select modes of Highway, Compass, Direction of wind etc.
⑤	ROTATION		Select Rotation or avoidance Only working on mode of Compass, Plotter
⑥/⑦	ESC / MENU		ESC : Escape from select or cancel current operation MENU : To activate Menu and move to prior menu
⑧	INPUT DIAL		INPUT : To activate selected menu. Setup menu of adjust ratio is activated in working screen Dial : To change menu list by dialing Steering can be corrected in Dial mode
⑨	LCD	5.6inch	All information relative to navigation

4.2 Configuration of Menu

4.2.1 Menu

1. Adjustment

- 1. Compass
- 2. Rudder
- 3. Remote

3. Option

- 1. Greenwich offset
- 2. Rotate angle
- 3. Weathercock
- 4. Gauge
- 5. Tank
- 6. Exercise

5. Measurement

- 1. Distance
- 2. Speed
- 3. Fuel
- 4. Temperature
- 5. Pressure Gauge

2. System setup

- 1. Language
- 2. Night mode
- 3. Key sound
- 4. Remote
- 5. Hardware setup
- 6. System data
- 7. Update
- 8. Initial setup

4. Alarm

- 1. Course error
- 2. Route leave error
- 3. Low power
- 4. Waypoint
- 5. Auto navigation

6. Self Test

- 1. System Monitoring
- 2. Memory test
- 3. Key test
- 4. Compass correction

4.2.2 Set for adjust ratio

Adjust Set

- 1. Variation
- 2. Wave height
- 3. RudderAngle Sensor
- 4. Screen Brightness

4.3 Screen of Display unit

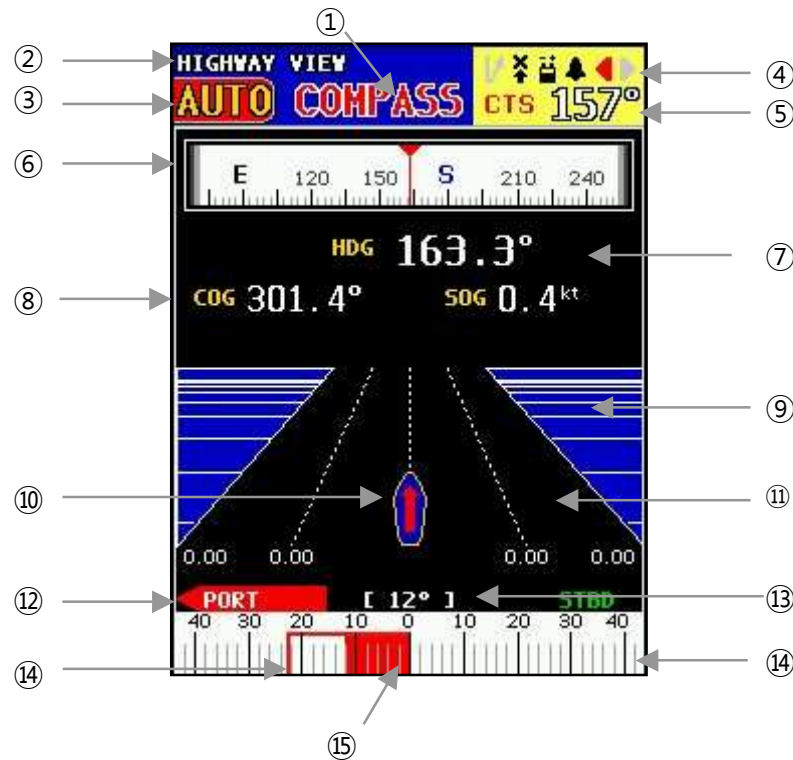

< Figure 4-2. Basic configuration of SAS-70 >

NO	FUNCTION
①	Current Steering mode. It consists of Compass, Plotter, Remote, Dial modes.
②	Screen modes. It consists of Highway, Compass, Weathercock, Gauge, Tank, Data screens.
③	Auto / Manual modes.
④	Status of warning setup / operating direction of Solenoid valve. (From the left, warning of wave deviation, heading signal, input power, other ones and operating direction of Sol-valve)
⑤	Setting value for Bearings angles of waypoints in Compass, Plotter mode. Able to set the bearings angles by turning a dial in Compass mode.
⑥	Current heading bearings angle as a picture of analogue type.
⑦	Current heading bearings angle as a numeric text type.
⑧	Information about navigation as such course, speed of ground, degrees of route deviation, distance for waypoint, bearings for waypoint, number of waypoint.
⑨	Speed of wave flowing in accordance with speed of ship.
⑩	Move to left/right in accordance with degrees of route deviation in a Plotter / Auto mode. (The speed is shown at below of a picture of the ship in case of installing of Speed log. The Speed log is an optional item.)
⑪	Degrees of deviation as a picture in Plotter/Auto mode. (Similar to traffic lanes of highway)
⑫	Operating status of Solenoid valve (left, right) and it is operating to the left in case ⑮ is calibrating on left side and to the right in case ⑮ is calibrating on right side.
⑬	Bar graph of Rudder Steering indicator showing current status. (Ex. The bearings of rudder is 12° of the left in the above.)
⑭	Remote rotation angles in more than 5° rotated (Remote Avoidance).
⑮	Current Rudder angles.

4.4 MANUAL STEERING (HAND)



■ Manual steering means that there is no control from auto steering device, and ship is under control of an operator. The relative information as such navigation is shown as current status in a screen.

1. Manual Steering status on [Manual] and Auto Steering status on [Auto] in a screen. Changed to auto steering mode, pressing [Manual] button.
2. In a manual steering mode, the operator handles with steering of ships.
3. Angle sensor indication and heading bearings are shown as a current status.

4.5 COMPASS STEERING

[NOTE] Wave height ratio and Rudder angle ratio should be adjusted properly

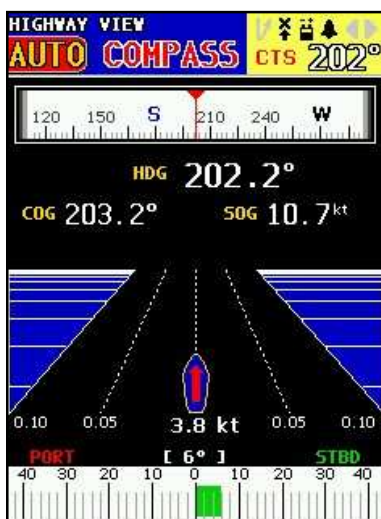

■ Compass steering is an auto steering method that enables the ship to navigate in straight way by setting the destined route making use of compass bearing connected to steering controller.

1. Select compass mode of compass (Remote should be at neutral position)
2. In screen, angle indicator and bearing and destined bearing and working direction of solenoid valve will be displayed.
3. The ships are adjusted by Remote Controller with alarming in case, the controller is turned more than 5° from neutral position. Then, it turns back to mode of Compass steering in putting the remote controller at neutral position.

4.6 PLOTTER STEERING

[NOTE] Wave height ratio and Rudder angle ratio should be adjusted properly



■ Plotter steering is to automatically navigate the ship by using GPS Plotter connected that gives the destined bearing.

1. Select mode of Plotter steering. (Remote should be at neutral position)
2. In screen, angle indicator and bearing and destined bearing and working direction of solenoid valve will be displayed.
3. The ships are adjusted by Remote Controller with alarming in case, the controller is turned more than 5° from neutral position. Then, it turns back to mode of Plotter steering in putting the remote controller at neutral position.

4.7 REMOTE STEERING



■ To row a ship by connected remote controller

1. Select Remote Steering mode.
2. In screen, angle indicator and bearing and destined bearing and working direction of solenoid valve will be displayed.
3. Heading bearings are shown.
4. Row a ship by remote controller.
5. Turn the controller with slow.

4.8 DIAL STEERING

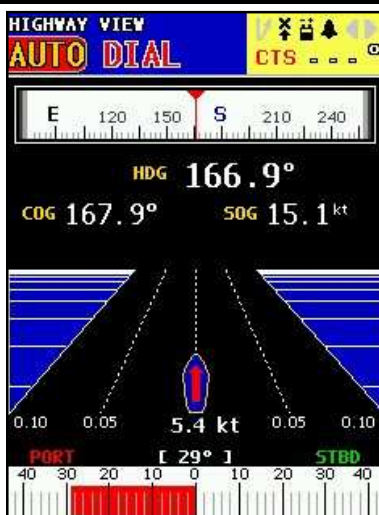



■ To row a ship by turning dial handle attached on front panel of indicator. (Similar with Remote Steering)

1. Select Dial Steering mode.
2. In screen, angle indicator and bearing and destined bearing and working direction of solenoid valve will be displayed.
3. Heading bearings and Rudder angle are shown at indicator of dial LCD.
4. Turn the handles with slow.

4.9 AVOIDANCE / ROTATION

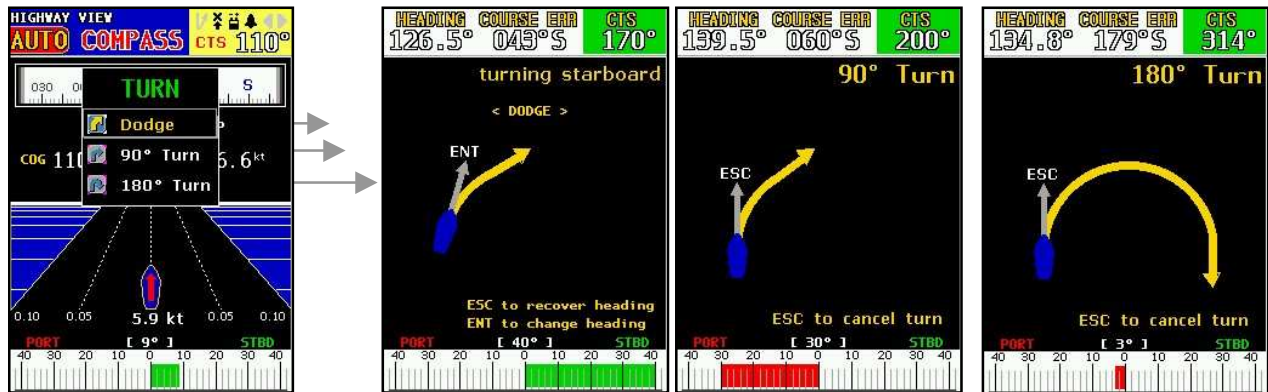
[NOTE] Avoidance / Rotation is only available with Compass, Plotter Steering modes.



Press  button, then menu to select [Avoid] , [90° Rotate] , [180° Rotate]. Move to the cursor onto required function by pressing  button, then the direction of avoidance/rotation by dialing [DIAL] button is decided and it starts working. Especially, the angle of avoidance can be changed continuously by dialing [DIAL] button in avoidance operation.

4.10 TYPES OF SCREENS FOR OTHER NAVIGATION INFORMATION

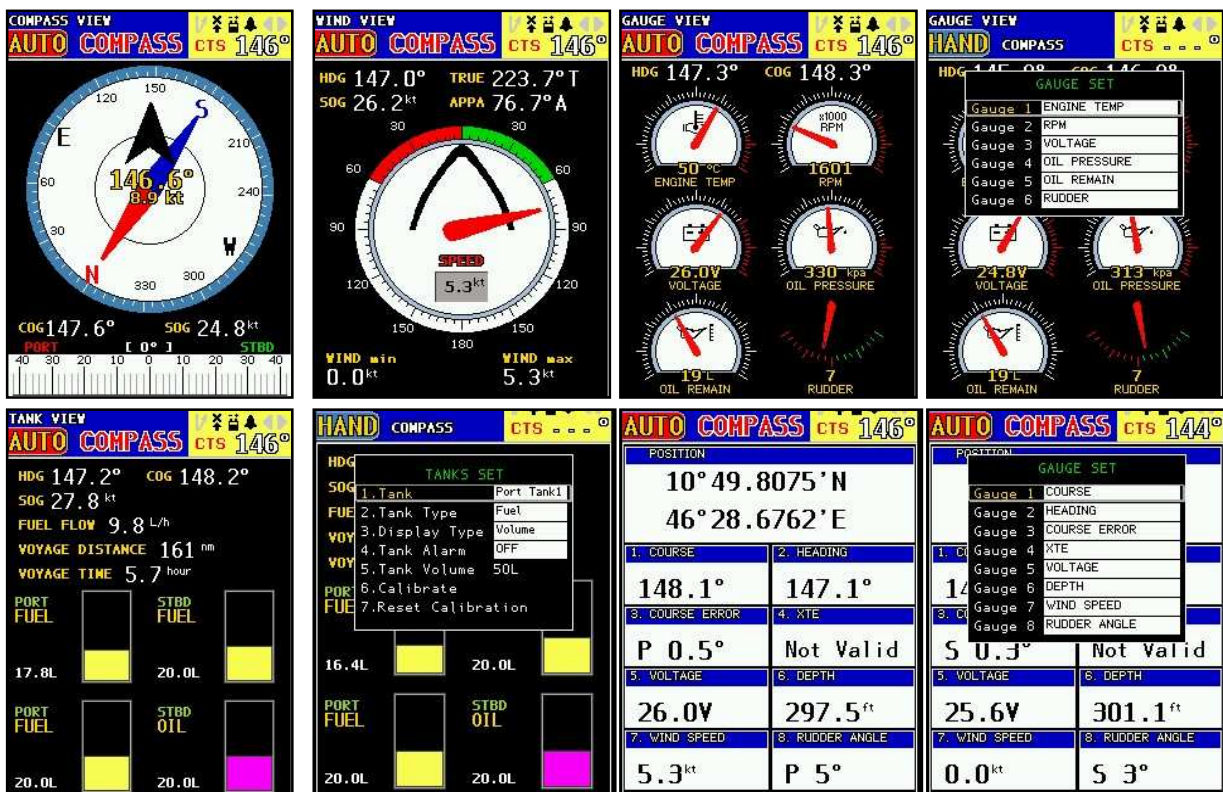

Wind direction / speed screen, Gauge screen, Tank screen works well in being equipped with sensor device of being sold as an optional item by Samyung ENC. (Refer to the instruction manual of the sensor device for "how to operate".)

Select the type in Gauge, Tank, Data screens by pressing menu-button once and it changes to basic menu screen by pressing the button once more.

4.11 ADJUSTMENT OF VARIATION

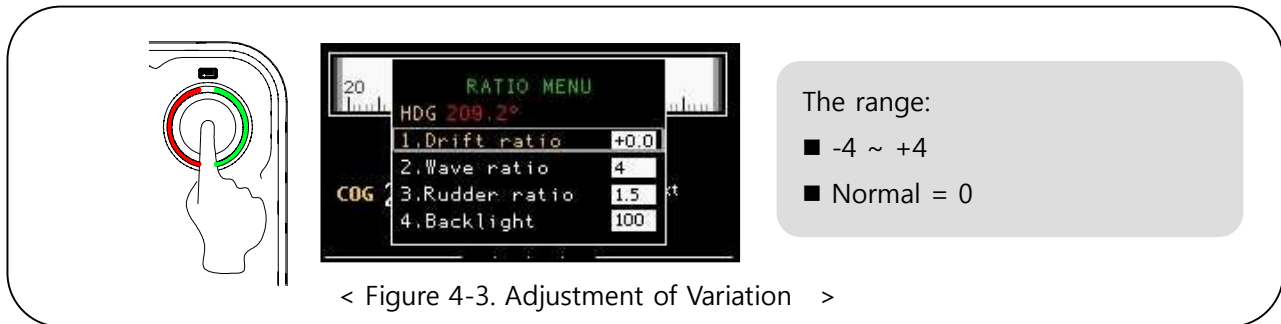

- ❖ Users need to adjust by dialing the dial with more detail even if it was adjusted by adjustment of Compass.
- ❖ It is adjusted in proportion as values set by variation ratio of Compass.
- ❖ After setting the values by dialing a [DIAL] button, save it by pressing button.

4.12 ADJUSTMENT OF WAVE HEIGHT RATIO

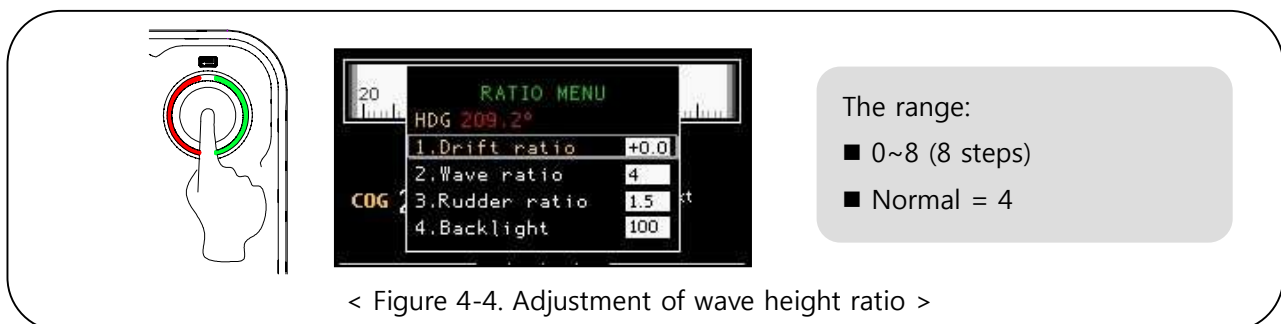

- ❖ The adjustment should be set in accordance with the height of wave and the appropriate value is "0" in weak wave, "8" in high wave.
- ❖ When heading bearings is out of way towards setup bearings / waypoint bearings in Compass or Plotter Steering mode, additional steering should be required. The adjustment of wave height ratio is to decide if users adjust the additional steering in time of how much degrees of heading bearings are out of way.
- ❖ In case of too low ratio of wave height, the heading bearings is shaking to left and right directions because of effect of wave and whenever it does, the rudder is worked due to the operation of solenoid valve.
- ❖ In case of too high ratio of wave height, the error of bearings get bigger in time of arriving at destination in Compass steering and the error of navigation route get much in time of navigating towards waypoint in Plotter steering.
 ("0" in Compass steering, "4" in Plotter steering)

4.13 ADJUSTMENT OF RUDDER ANGLE RATIO

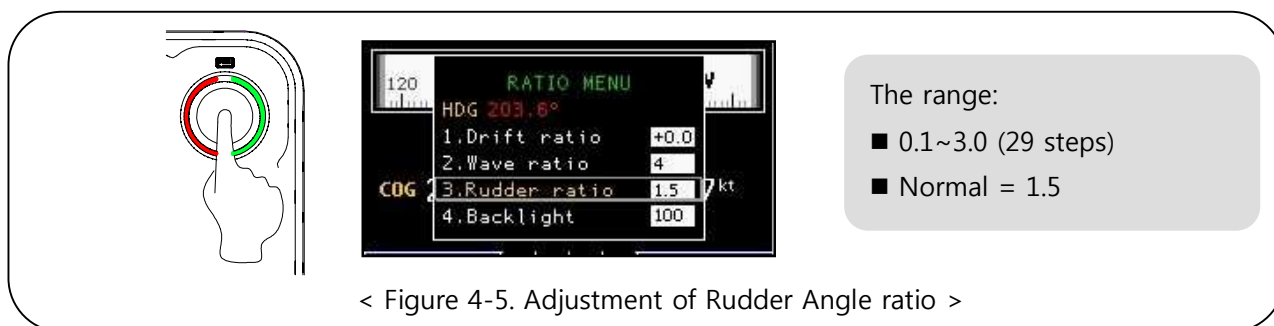

- ❖ The adjustment should be set in accordance with size, weight of ship, wind, wave, current and so on and especially, it is affected by wave, wind, current. The appropriate value is "1.5" in normal and this rudder angle ratio is worked at Compass / Plotter auto steering.
- ❖ In case of too low ratio of rudder angle, when the bearing of own ship is different with one of waypoint by any reasons, it takes much time to equal the difference of bearings. In case of too high ratio of rudder angle, when the bearing of own ship is different with one of waypoint by any reasons, it takes less time to equal the difference of bearings, but the heading of ship might be shook to left and right directions and it might be navigated with zigzag.
- ❖ When heading bearings is out of way towards setup bearings in Compass or Plotter Steering mode, the adjustment of rudder angle ratio is to decide if users adjust the additional steering in time of how much degrees of heading bearings are out of way. When heading bearings is 7° out of way from one of waypoint, if putting 7° of additional steering, the rudder angle ratio is 1.
- ❖ To adjust the ratio of rudder angle, you can dial a [DIAL] button on front panel. It is higher in dialing to right direction and lower in dialing to left direction.
- ❖ The rudder angle ratio is changed from 0.1 to 3.0 with 0.1 steps.

4.14 ADJUSTMENT OF SCREEN BRIGHTNESS

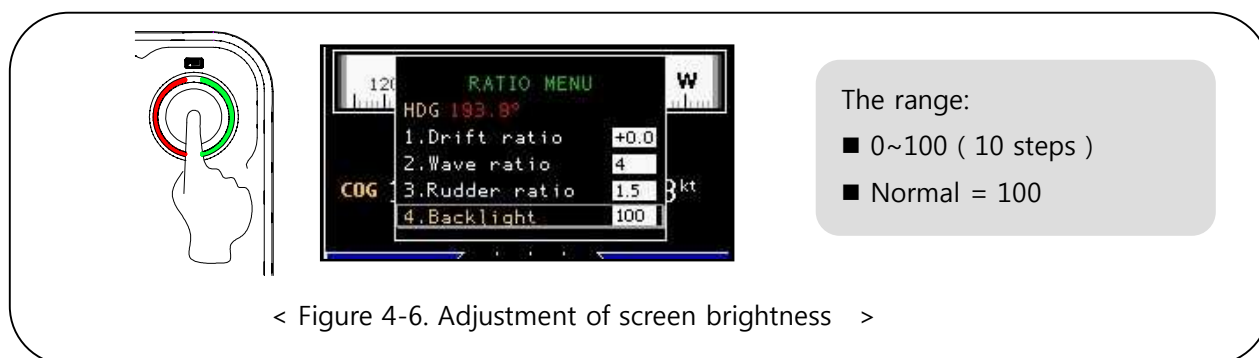

- ❖ Setting is available from 0 to 100.
- ❖ After setting the brightness by dialing [DIAL] button, save the current status by pressing  button.

4.15 FUNCTIONS OF REMOTE CONTROLLER

4.15.1 Remote Controller of RC-10A

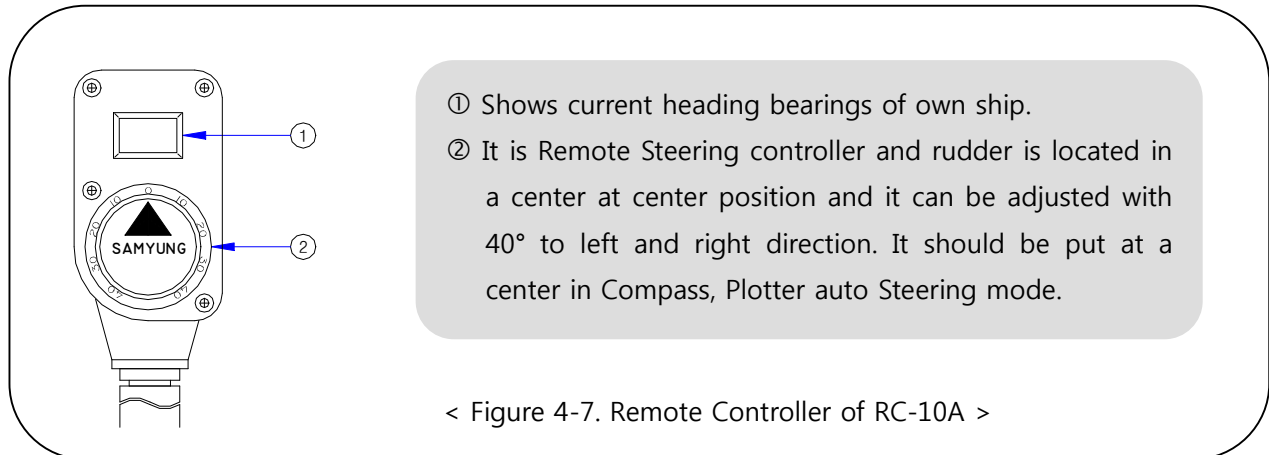

Chapter 5. System Installation

5.1 BEFORE INSTALLATION

Avoid mounting as follows

- ❖ Exposed to rain or sea water
- ❖ Difficult places to check, to repair and to plumb.
- ❖ Exposed to direct rays and hot temperature
- ❖ Exposed to severe vibration like near by engine

5.2 CONFIGURATION OF SYSTEM

The system is configured as followings.

ITEM	MODEL	Q'TY	REMARK
Display	SAS-70	1 EA	
Controller	SAS-70C	1 EA	
Remote Adapter	SAS-70A	1 EA	
Solenoid Valve	SV-20	1 EA	
Direction Sensor	ES-95	1 EA	
Transmitter	FS-80B	1 EA	
Rudder Angle Indicator	FM-80B	1 EA	
Remote Controller	RC-10A(OPTION RC-30A)	1 EA	
Installation material	-	1 SET	Ref. PACKING LIST
Engine control	SM-975A	1 SET	OPTION

5.3 INSTALLATION FOR AUTO PILOT

5.3.1 Installation for display units

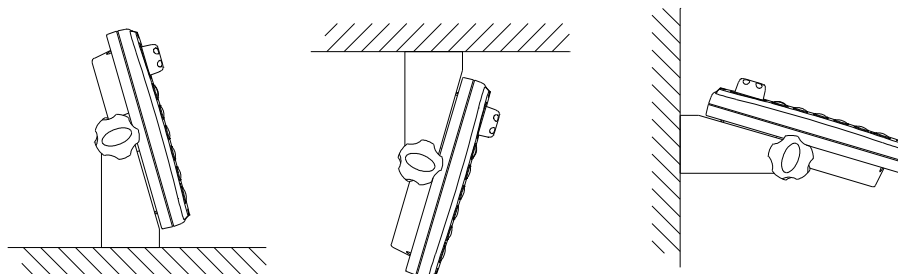

< Figure 5-1. Installation for display units >

- Select a spot for display installation and fix an installation bar with screws.
- Fix the display onto an installation bar
- Install it for easy operation in a spot not affecting to ship navigation
- Refer to Chapter 7. for detail measurement

5.3.2 Installation for Compass sensor (Electronic Compass)

- ❖ To install direction sensor, keeping it away from the place where not only there is magnetism effecting to sensor performance but also solenoid valve, motor or electric cable. The most efficient place to install is lower part of hull and center of hull.

※ **Top bridge is strongly recommendable for installation position.**

- ❖ Install to follow white line on the side of direction sensor. This marked direction have to face direction of the bow.
- ❖ To install direction sensor, fix the sensor bracket to hull or hull structure and sensors direction should be installed as following figures. Minor direction error can be corrected by magnetic difference correcting at initial setting.

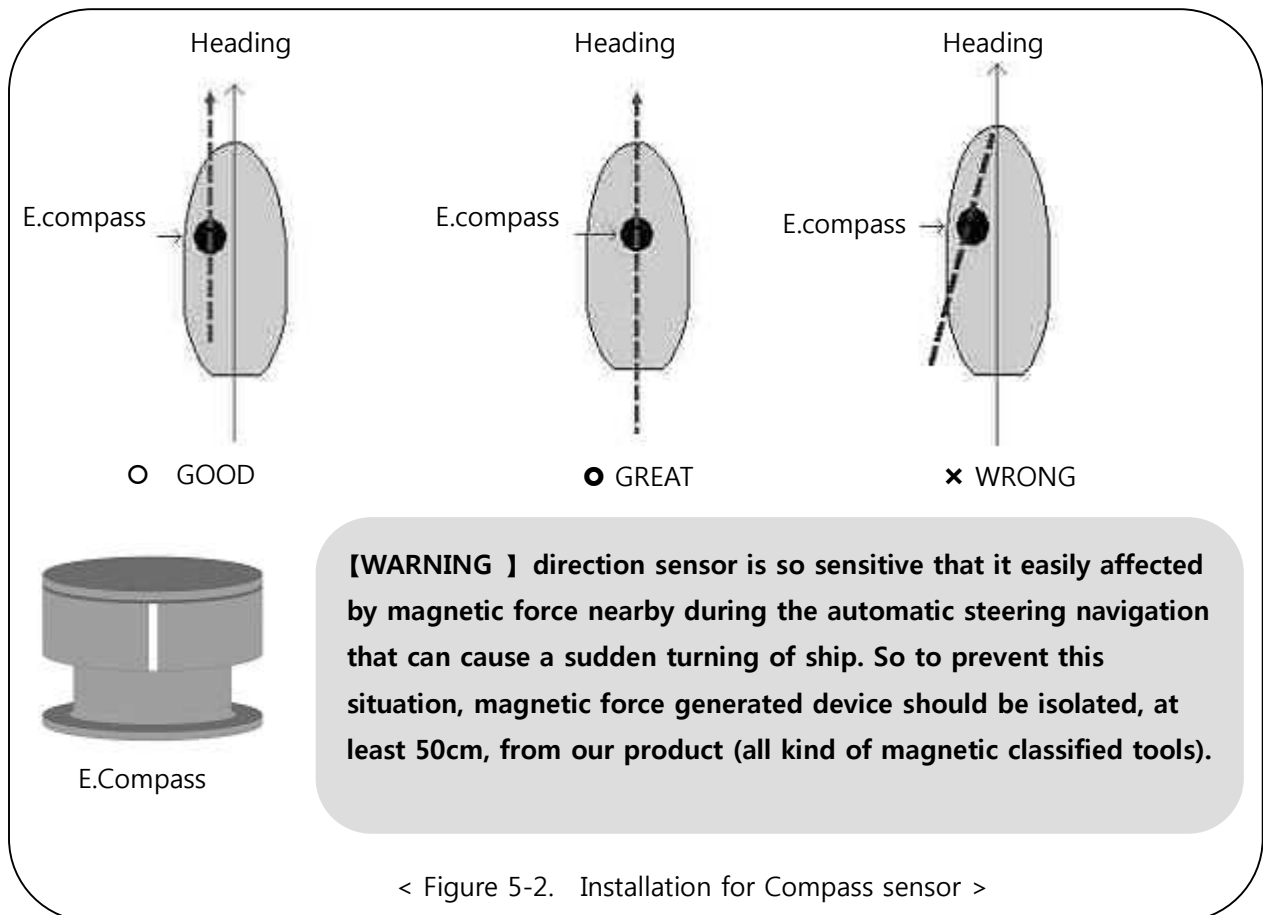

5.3.3. Installation for Solenoid valve

- ❖ Install solenoid valve close to manual steering wheel. It makes easy to do piping work for hydraulic system. If it is not possible, install it near at oil pump or other places.
- ❖ Making 4 holes in 8mm diameter at the position of installation and fix it with bolt and nut.

[WARNING] : Install Electronic coil horizontally. Otherwise it can cause poor function.

- ❖ Install it in easy position to control the oil regulator located in solenoid valve unit.

5.3.4 Installation for Transmitter

- ❖ Any directions are available for installation direction of transmitter (angle sensor) but following instructions are recommended.
- ❖ Make 4 holes by 9mm dia. at installation table and fix transmitter onto it with bolts and nuts.

[WARNING] Avoid installing places where exposed to a strong vibration, high temperature, sea

- ❖ Make a hole or fix the bolt (size : 8mm dia/lenth 30mm) at the same distance (refer to below figure V1) with transmitter side' connecting rod from the center of the tiller and link it with connecting rod, then tiller's steering angle and transmitter's steering angle will become same. If user wants its angle to be accurate, adjust V1 with adjusting screw until V1 and V2 become same.
- ❖ Install connecting rod horizontally by adjusting height of transmitter (angle sensor).
- ❖ Install steering wheel angle to become central position. When tiller is located to central position. (After installation, adjust it with adjusting screws (H2 interval) maximum adjust range of connecting rod is within 20mm, if you need more adjustment than 20mm, replace it with others.)
- ❖ After finishing installation, the distance between H1 and H2 have to be equivalent (V1 and V2 also) as followings figure.

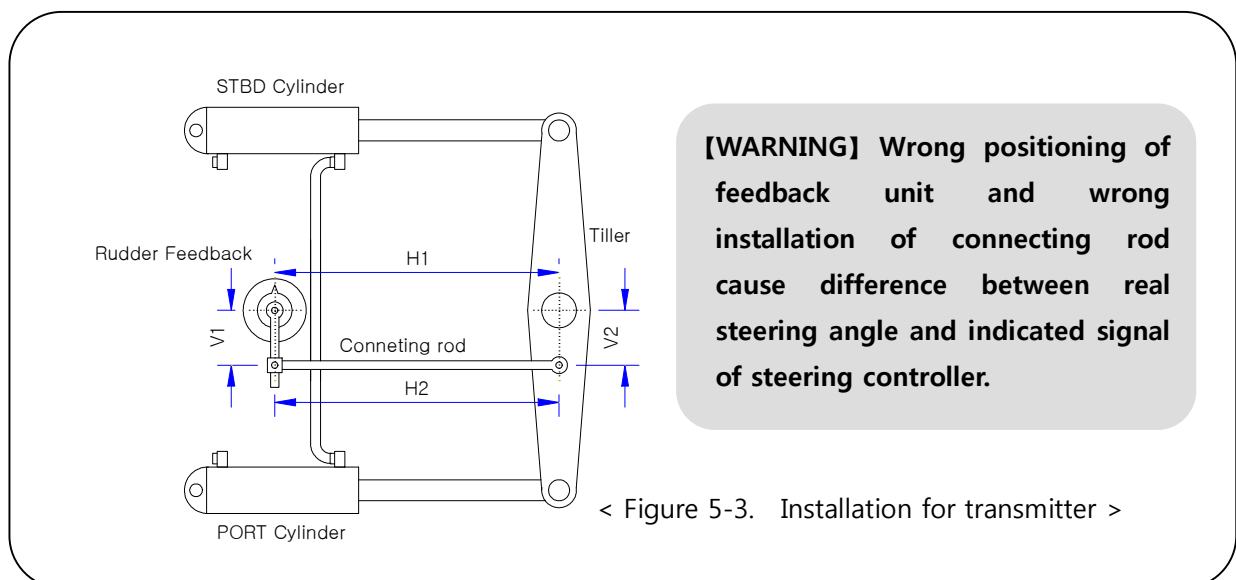

< Figure 5-3. Installation for transmitter >

Chapter 6. Hydraulic Piping

6.1 Before Hydraulic piping

Refer to the Piping Diagram to ensure that there is nothing wrong about the piping.

- ❖ Connect carefully the joints of the copper pipe and each part to the direction of the sleeve.
- ❖ In cutting the copper tube, use a pipe cutter only and cut the up-and-down at a right angle.

[WARNING] Cutting with a saw will create any chips that cause the breakdown.

- ❖ Fix the copper pipe with a proper press-button device.

[REF] Fix it at every 1m in case of straight line and at every 30Cm in case of curve.

- ❖ After completing the piping, clean the surroundings of the pipes and disassemble the linked part and brush off the inner copper pipe.
- ❖ After finishing brushing, reassemble it and make some air evacuation according to the manual of the steering wheel.
- ❖ Oil filter should be installed in the oil tank. (By placing a permanent magnet inside the oil tank, the iron substance can be removed.)
- ❖ Clean the oil tank and the pipes. Then change the oil with new replacement oil.
- ❖ When piping with rubber oil hoses, the ends of the hoses should be firmly connected.
- ❖ Complete all the procedures and connect it to the steering wheel controller (it refers to "electrical wiring".) and start the engine and check if the tiller works normally through turning the adjustor of the remote control. If it moves to the opposite direction, correct it for SAS-7 use of SOLENOID electrical wiring. (This is connected to the terminal plate) and connect it to the properly working spot.
- ❖ In installing oil-pressure pipes, if there is any part that contacts against the hull, tighten it firmly by using such fasteners as PCV belt. In case of the copper pipe, wrap it with rubber and then tighten it.
- ❖ The followings are the abbreviations used in the pipe distribution diagram.
 - T : This refers to the pipe connecting part which is linked to the oil tank.
 - P : This refers to the pipe connecting part which is linked to the oil pump.
 - A : Also expressed 'L' (the opitrol of the manual steering wheel), this refers to the pipe connecting part where the tiller moves clockwise (Ship will turn left) when the oil pressure is made in A pipe.
 - B : Also expressed 'R' (the opitrol of the manual steering wheel), this refers to the pipe connecting part where the tiller moves counter-clockwise (Ship will turn right) when the oil pressure is made in B pipe.

6.2 Piping diagram before installation for Solenoid valve

- ❖ This instruction manual explains about the installation procedures, based on those ships that are equipped with the following oil-pressure circuit. If you have any questions on other oil pressure systems, contact any specialist for more help.

[WARNING] A is also expressed as 'R' and B is 'L' in the opitrol pipe of the manual steering.

- ❖ After the installation of the oil-pressure pipes and electrical circuits, it is sometimes required to adjust the solenoid oil pressure controller. For example, when the rudder is controlled by solenoid under the remote mode, the compass mode and the plotter

steering mode, you need to adjust it if the rudder movement is too speedy or too slow. The oil controller is installed in the bottom part of the solenoid valve.

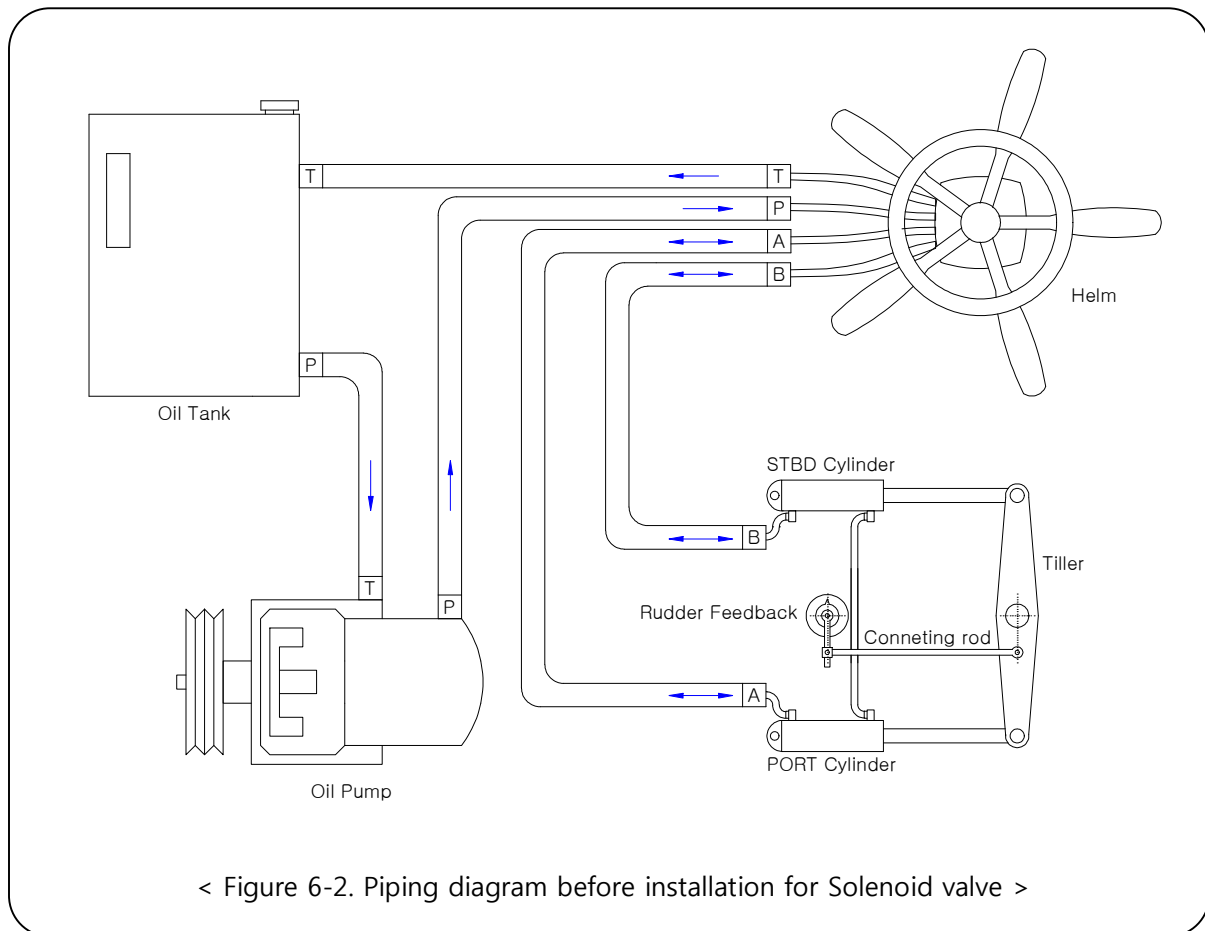

6.3 Piping diagram after installation for Solenoid valve

Refer to the following procedures to connect the solenoid valve in the existing oil pressure pipes.

- ❖ Separate "P" pipe from the oil pump. (The "P" pipe is linked to the opitrol)
- ❖ Connect "P" of the oil pump and the oil controller (Relief valve). Then connect "P" of the solenoid valve to the opposite side where "P" of the oil pump "P" is set in.
- ❖ Connect "T" of the solenoid to "P" of the opitrol.
- ❖ Separate the pipes linked between "A(R)" of the opitrol and "A" of the left side cylinder.
- ❖ Use T-type joint to connect "A" of the solenoid valve, "A(R)" of the opitrol and "A" of the left side cylinder together.
- ❖ Separate the pipes linked between "B(L)" of the opitrol and "B" of the right side cylinder.
- ❖ Use T-type joint to connect "B" of the solenoid valve, "B(L)" of the opitrol and "B" of the left side cylinder together.
- ❖ Use T-type joint to connect "T" of the oil tank, the oil controller and "T" of the opitrol together.

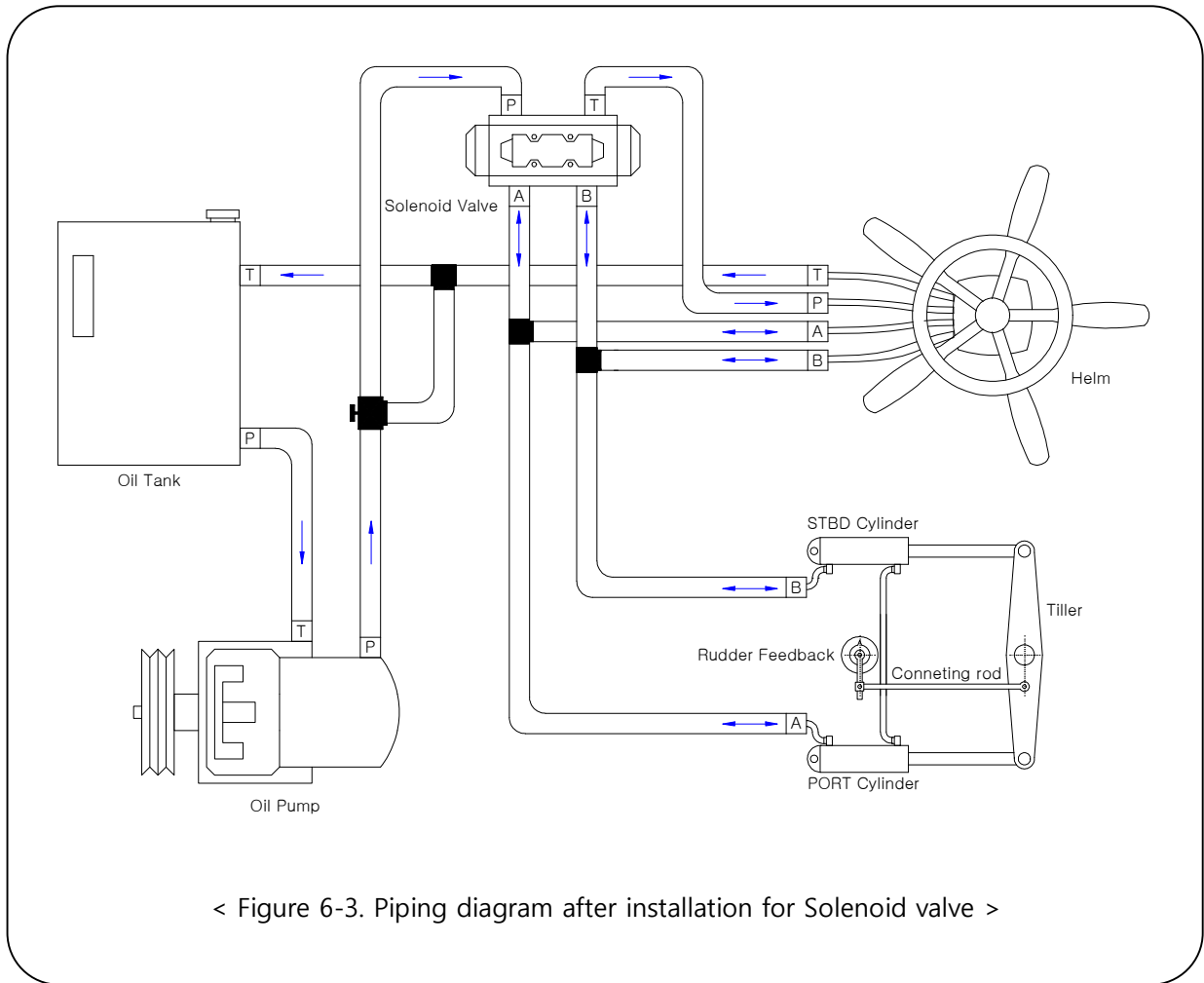

6.4 Piping diagram at a cylinder type

When the oil-pressure is given in the pipes connected to the solenoid, the Left(B) pipe is the pipe to which the ship direction turns left while the Right(A) pipe is the pipe to which the ship direction turns right. So it should be piped as shown below.

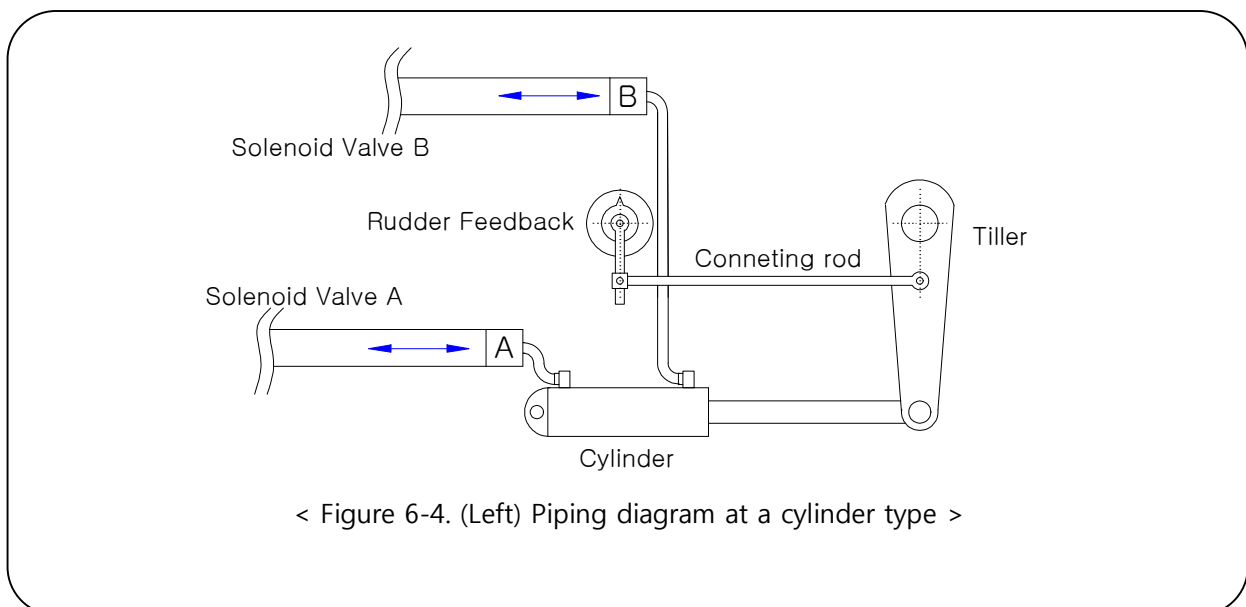

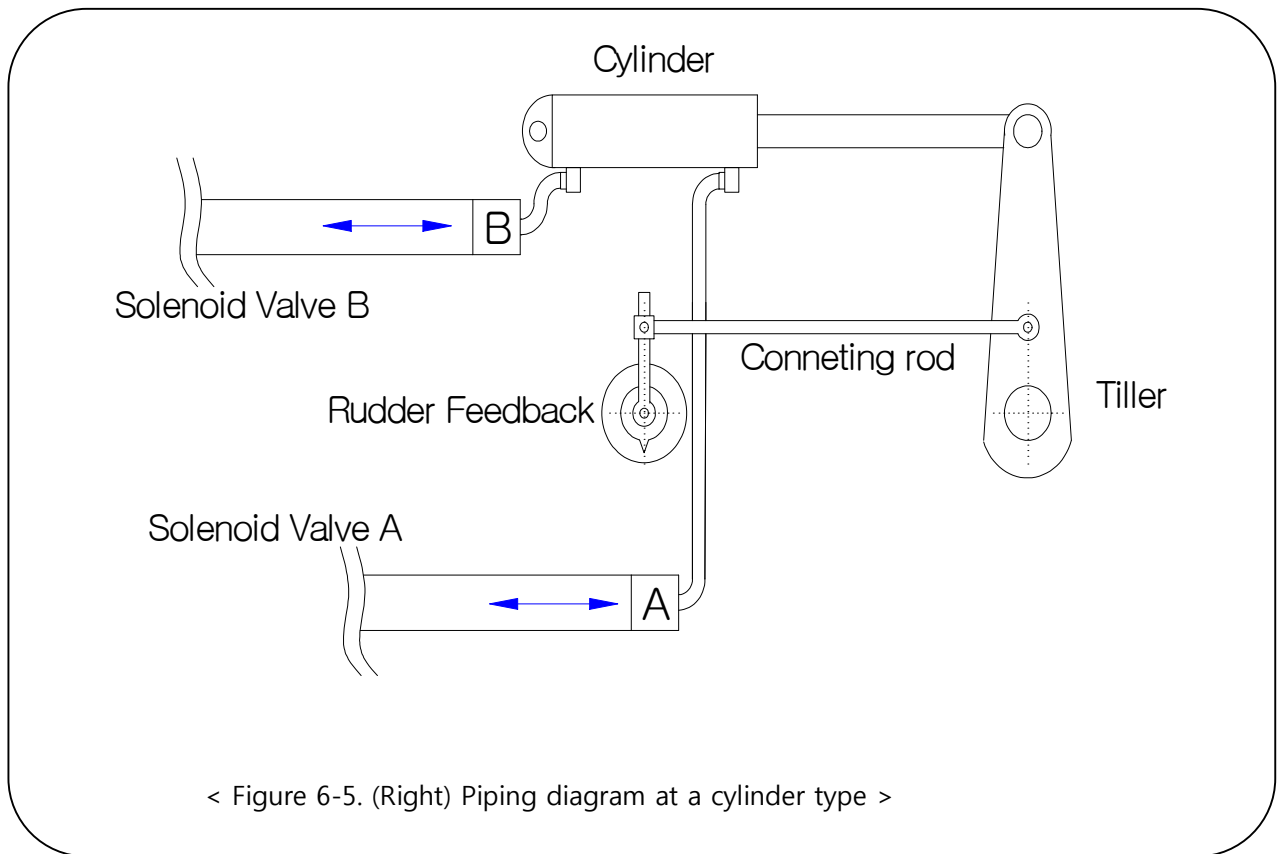

Chapter 7. Electric Diagram

7.1 Before hydraulic piping

Before setting the wires, please abide by the following instructions. Improper handling may cause any serious electric shocks or damages to the equipment.

- ❖ Make sure that the power supply is closed.
- ❖ Check out DC 24V of the power terminal (Black, White, G). Never connect the opposite way. The polarities of power are white for (+) and black for (-).
- ❖ For linking the terminal box, confirm the terminal signal and the cable position and then, work on the exact connection.
- ❖ After completing piping, check the status of the terminal box once again.

7.2 Interference to Radio equipment

It is often vulnerable to the interferences of radios. Keep away the autopilot-related cables from other cables if possible.

In case that the autopilot is interfered by radio equipment, for the most part, the interference is expressed through the change of the bow direction. If there is any change of the bow direction while any transmitting is made by any radios, it means the system is interfered. In order to avoid this, please keep the followings in mind.

- ❖ Keep the steering wheel, the direction sensor from antenna as far as possible.
- ❖ Keep the autopilot-related cable from other radio cables as far as possible.
- ❖ Do not install the steering wheel around the coax cables stretching from radio equipment to their antennas.

7.3 Cautions in initial Power-On

Please be careful about the following instructions when the power is supplied for the first time.



- ❖ Check if the plumbing is correctly designed.
- ❖ Make sure that the specifications of the equipment, including the battery voltage are correct.
- ❖ If the engine start is turned after turning on the power, there are some possibilities that a drastic change or any abnormal malfunction may happen. When power on, it will make the buzzer ringing, LCD display of the panel center will show the changed mode status in current use (the selected mode). If it does not show anything even after the power is on, the fuse is considered as broken. Find out the cause as fuses are installed at the back of the main unit, each one for 3A and for 10A respectively. Then replace it with a spare fuse if necessary.

Chapter 8. Initial Setup after installation

8.1 Initial setup

As the equipment is delivered from the factory, going through all the detailed adjustments, users are not required to set up the most functions but the setup of functions as such solenoid valve, compass, rudder, neutrality of remote, characteristic of oil pressure is required. The initial setup is as follows.

8.1.1 Power ON/OFF

- ❖ Turn on Power switch of control part (SAS-70C) and press  button on display part (SAS-70). Then, the following LCD screen comes on.
- ❖ To turn off power of display, press  button for 2 seconds.
- ❖ Press  button, then the following figure as such < Figure 8-2. > comes on. The user can set among categories on menu.



< Figure 8-1. Power ON/OFF >

8.1.2 Rudder setup



< Figure 8-2. Rudder Setup menu >

❖ Rudder neutral position setup < Figure 8-2. Reference >

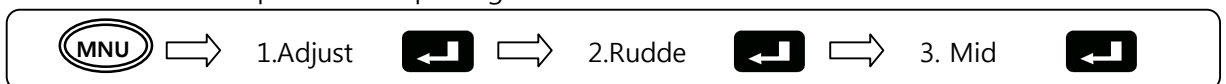

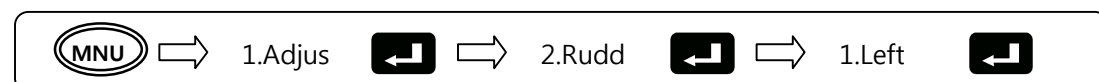

- ① In installed Rudder Angle Indicator: Put the arrow of rudder angle indicator onto a center "0" by rolling handle of manual steering. Move a cursor onto [SET], save a value by pressing button. Select [ESC] to cancel the value then the previous value is kept.
- ② In not installed Rudder Angle Indicator: After moving a cylinder onto a center by rolling handle of manual steering, put the arrow of transmitter onto a center "0". Move a cursor onto [SET], save a value by pressing button. Select [ESC] to cancel the value then the previous value is kept.

❖ Rudder left position setup < Figure 8-2. Reference >





- ① In installed Rudder Angle Indicator: Put the arrow of rudder angle indicator onto

max "40" of left by rolling handle of manual steering. The value of screen is changeable in accordance with angles to be rolled by the steering. Move a cursor onto [SELECT], save a value by pressing  button. Select [ESC] to cancel the value then the previous value is kept.

- ② In not installed Rudder Angle Indicator: After moving a cylinder towards left-end by obitrol, then move a cursor onto [SELECT], save a value by pressing  button. Select [ESC] to cancel the value then the previous value is kept.

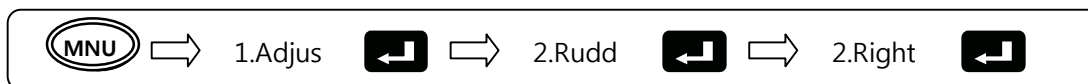
❖ Rudder right position setup < Figure 8-2. Reference >



- ① In installed Rudder Angle Indicator: Put the arrow of rudder angle indicator onto max "40" of right by rolling handle of manual steering. The value of screen is changeable in accordance with angles to be rolled by the steering. Move a cursor onto [SELECT], save a value by pressing  button. Select [ESC] to cancel the value then the previous value is kept.
- ② In not installed Rudder Angle Indicator: After moving a cylinder towards right-end by rolling handle if manual steering, then move a cursor onto [SELECT], save a value by pressing  button. Select [ESC] to cancel the value then the previous value is kept.

❖ Rudder sensitivity setup

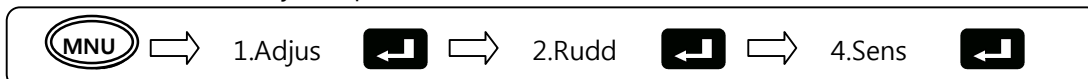

While a ship is under way in the autopilot mode, you can recognize that the rudder continuously swings a little mainly due to wind or tidal current. If this continues for a long time, the cylinder and the oil-pressure related devices may have a shortened lifetime. So the sensitivity of the rudder should be highly raised in such cases.

- ① The setting value is increased in dialing [DIAL] to right onto a screen of Rudder Sensitivity of <Figure 8-2>. The rudder sensitivity is dull and possible to adjust up to the maximum 5.0°.
- ② In dialing [DIAL] to left onto the menu, the setting value is decreased. The rudder sensitivity is getting higher and possible to adjust up to the minimum 0.5°.
- ③ The sensitivity value is set to 1.0 when SAS-70 is released from the factory.
- ④ Press  button to save the value and in selecting [ESC] to cancel, the previous value is kept.

❖ Gauge Neutral

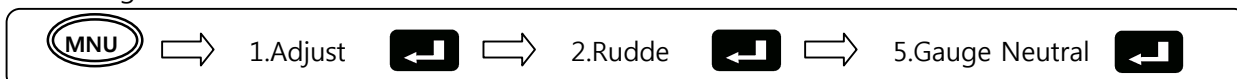



- ① Only available with a case being equipped with Rudder Angle Indicator. Match

Rudder on exact center by rolling the steering wheel and adjust the arrow of rudder

- ② angle indicator toward "0" direction, then press  button.

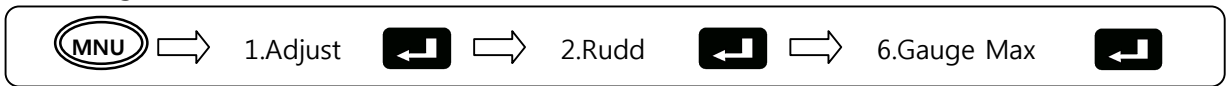
❖ Gauge Max



- ① Only available with a case being equipped with Rudder Angle Indicator. Match Rudder on exact 40 degrees by rolling the steering wheel and adjust the arrow of rudder angle indicator toward "40" direction, then  button.

❖ Hydro property

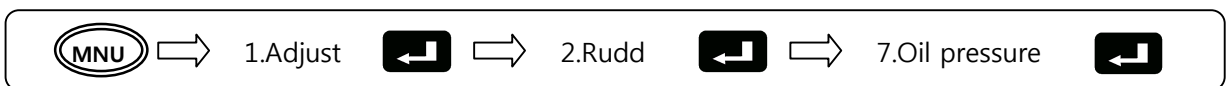

- ① a compensator of the oil-pressure device, adjust the proper values depending on the control status of the solenoid valve, the properties of the oil pump and the properties of the cylinder, which allows the rudder to have a smooth movement. (If low figures, it works smoothly and if high figures, it works harder.
- ② By dialing [DIAL] to left/right to change the setting value. (Available to adjust from 01 to 99 step)
- ③ Press  button to set the above value. Select [ESC] to cancel, then the previous value is kept.

8.1.3 Remote setup



[MENU]



[ADJUST]



[REMOTE ADJUST]

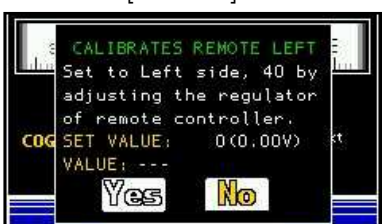

[REMOTE LEFT]

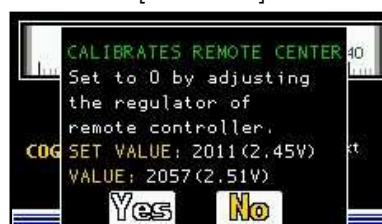

[REMOTE MIDDLE]



[리모트우측]

< Figure 8-3. Remote adjust >

❖ Remote left setup

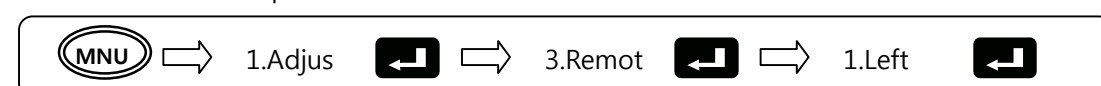

- ①
- ① Match to max "40" of left direction by rolling Remote controller.
- ② Move a cursor onto [SET] and press  button to save it. Select [ESC] to cancel then the previous value is kept.

❖ Remote right setup

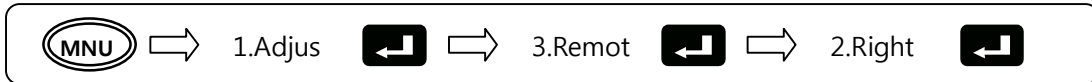

- ① Match to max "40" of right direction by rolling Remote controller.
- ② Move a cursor onto [SET] and press  button to save it. Select [ESC] to cancel then the previous value is kept.

❖ Remote middle setup

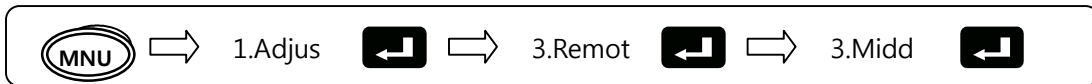

- ① Match to middle value of "0" by rolling Remote controller.
- ② Move a cursor onto [SET] and press  button to save it. Select [ESC] to cancel then the previous value is kept.

8.1.4 Compass adjustment



[MENU]



[ADJUST]

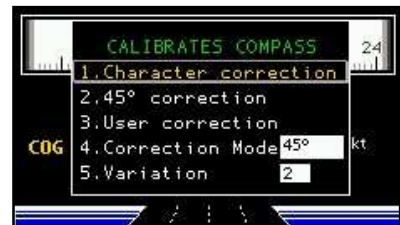

[COMPASS ADJUST]



[SHIP CALIBRATE]



[45° ADJUST]



[USER ADJUST]

< Figure 8-4. Compass Adjust >

What Compass Adjust is, when current prow direction is not the same with true direction, revise electronic compass and make it same with true direction. An earth magnetic field of south and north

does not match with earth's north/south pole exactly. (The Republic of Korea's variation is around +7.)
 A standard direction for revision should be true north and should be revised by GPS or GPS Plotter. Revision should be done after full installation and when iron frame, which is around electronic compass sensor is changed as well.

❖ Ship calibrate

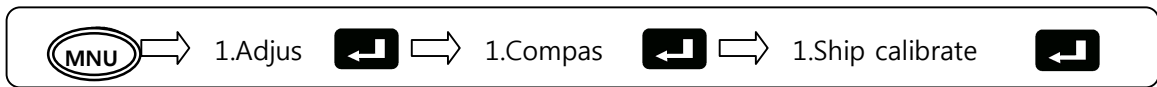



[Ship calibrate] is setup direction by rotating a ship and the procedure of [Ship calibrate] is as followings.

- ① When [Ship calibrated screen] is appeared, take a ship one and half slowly. In a screen, the status is shown as a percentage graph. For the exact revision, make a ship to rotate bigger.
- ② When the revision is reached at 100% status, move a cursor onto [SET] and press  button to save it. Press [ESC] to cancel it then the previous value is kept. To set it again, you need to rotate a ship again so that you need to take care of setup. If you saved correction value, do straight navigation by 45° or 90° range. Compare this with GPS plotter direction and it is complete Correction if the range of error is ±5°.

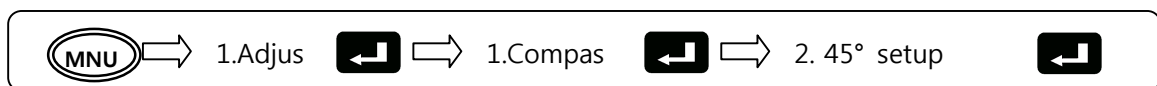
❖ 45° Setup



[45° Setup] is revised the difference of compass for 8 directions navigating each 45° step based on 0° for test. After revised [Ship calibrate], execute [45° Setup] for more exact direction setup.

- ① When [45° Setup screen] is appeared, Move a cursor to each (0°, 45°, 90°, 135°, 180°, 225°, 270°, 315°) divided by 8 items and press  button → [Dial rotation] →  button in order for correction.
- ② Keep a current direction to current setting angle (ex. 90°) and check it with direction values of GPS under navigation for 1 minute then revise the difference by dialing [DIAL].
- ③ Press  button to save the revised value and press [ESC] to cancel it then the previous value is kept.

❖ User Revise

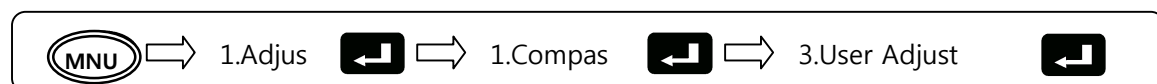

After [Ship Calibrate] set, adjust direction with 5° Range if it needs minute direction value

depends on user.

- ① Set wave height ratio from 0° to 355° with 5° range and revise the difference by dialing [DIAL].
- ② Press  button to save the revised value and press [ESC] to cancel it then the previous value is kept.

❖ Mode selection

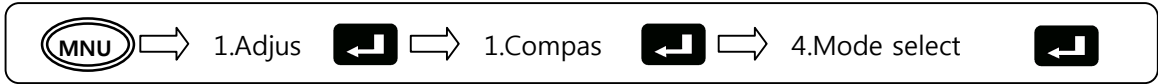

Select if use user revision value or direction value which is revised by 45°Range during navigation.

❖ Compass variation ratio

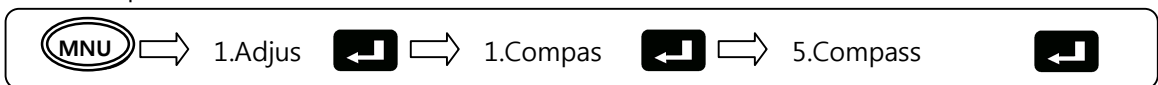

It is for more minute Correction during navigation even a variation is adjusted by Magnetic Variation Set.

- ① Set the ratio by dialing [DIAL] and press  button to save.
- ② The [revised ratio] changed by dialing [DIAL] is revised in accordance with this setting ratio.

8.1.5 System setup

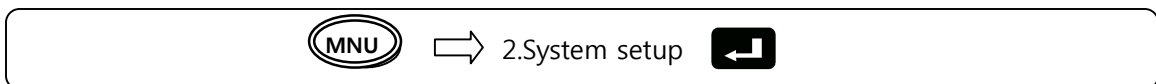

[MENU]



[SYSTEM]

< Figure 8-5. System setup >

NO	MENU	FUNCTION
1	Language	Korean / English
2	Night mode	Select day / night / auto mode of screen Selecting "auto", it is day mode from 06 ~ 18 o'clock and night mode from 18 ~ 06 o'clock. Working in connecting to Plotter..
3	Key sound	Select click sound of ON / OFF
4	Remote mode	Select remote mode of ON / OFF
5	Hardware	Select end-connecting resistance of ON / OFF, rudder magnet of ON / OFF

6	System info.	Enable to view of system information
7	Update	Only available function for registered engineers
8	Initial setup	Return all set values to an initial factory status

8.1.6 Option, Warning, Measurement



[MENU]



[OPTION]



[WARNING]



[MEASUREMENT]

< Figure 8-6. Option, measurement, warning >

NO	MENU	FUNCTION
1	3. Option	Set offset for standard time, rotating angles on rotate mode (5°~30°, 5°step), Set if Weathercock, gauge, tank, exercise screen are displayed
2	4.Warning	Set range of warning or make ON/OFF. Warning icon is activated in setting each warning or making ON.
3	5.Measurement	Set how to express the measurement (unit) for data showing in navigation screen.

8.1.7 Self test result

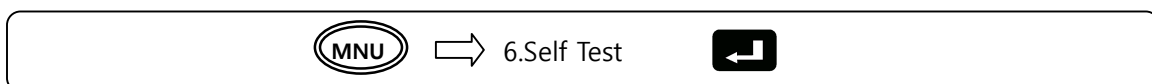

< Figure 8-7. Self test >

NO	MENU	FUNCTION
1	System Monitoring	It consists of 2 screens to supervise basic data input by this pilot system and other information both. Especially there are Rudder, Remote, Compass X, Compass Y, Compass R, Power Voltage with A/D values. When dialing a DIAL to right direction, possible to view other information.
2	Memory Test	Indicated normal / error status after checking out inter memory for control unit or indicator device.
3	Key Test	Check out status of functional keys SAS-70. Valuable keys are [Left dial], [Right Dial], [Confirm], [ESC], [MENU], [ROTATE], [SCREEN], [MANUAL], [MODE]. Press [ESC] button more than 3 times to return a previous menu.
4	Compass Revised values	Capable to view values of [Ship calibrate] and [45° setup] set by SAS-70. The calibrate values means max value and minimum value among A/D values input thru X-channel, Y-channel during rotation for ship calibration.

8.1.8 Adjustment for Solenoid valve

Not related to security issue in direct and if the adjustment is wrong set, the efficiency of unit is decreased so that it should be adjusted after installed circuit of oil pressure / electric circuit.

[WARNING] If solenoid is operated in conditions of closing status or lower controlling status for oil volume of the controller, the heats take place in the pressure oil.

❖ SV - 20

- ① After completely installed, put the steering controller onto a neutral position and select [REMOTE] mode among steering modes. Then, if the rudder is moving to end-left or end-right direction, switch black cable and white cable of solenoid.
- ② Put the steering controller onto end-left (-40°) seeing the movement of rudder and after awaiting for reaching to end-left point, roll the steering controller to end-right (+40°) position seeing a clock rapidly.
- ③ Check the time that rudder is moving from end-left to end-right position and control the valve oil-volume controller to reach for about 10 ~ 15 seconds.
- ③ As proceeding the above step of ② and ③ phases, adjust the time (time of moving from end-left to end-right and of moving from end-right to end-left) to reach for about 10 ~ 15 seconds continuously. (When the time of moving from end-left to end-right position is adjusted the time of moving from end-right to end-left position is same adjusted.)

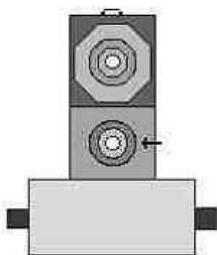

[REF] In case of adjusting the oil volume, speed adjustment of left-right / right-left direction should be done separately due to the controllers are located each other in SV-20. (" ← " Controller for oil volume)

< Figure 8-8. SV – 20 Solenoid valve >

8.2 Self Test

The self testing value can vary each time, and the numbers can be used by specialists in SAMYUNG to figure out the system performance according to diagnosis condition; therefore, when any trouble cannot be shot out, and sent this form to A/S Center, it will be facilitated the A/S procedure faster.

SELF TEST REPORT		Vessel Name	Installed date	
		Serial number	Test date	
			Inspector	
NO	TEST LIST	TEST CONDITION		RESULT VALUE
1	Self Test - System Monitoring - (1)	Transmit -40°, Rudder value (A/D)		()
		Transmit -0°, Rudder value (A/D)		()
		Transmit +40°, Rudder value (A/D)		()
2	Same as above (2)	Remote Controller -40°, Remote value (A/D)		()
		Remote Controller -0°, Remote value (A/D)		()
		Remote Controller +40°, Remote value (A/D)		()
3	Same as above (3~4)	Value of "Heading" 0°, Compass(X / Y) value		(/)
		Value of "Heading" 90°, Compass(X / Y) value		(/)
		Value of "Heading" 180°, Compass(X / Y) value		(/)
		Value of "Heading" 270°, Compass(X / Y) value		(/)
4	Same as above (5)	Compass R:		()
5	Same as above (6)	Power Voltage:		()
6	Same as above (7~10)	Compass variation/the ratio/wave height ratio/Rudder Steering ratio:		(/ / /)
7	Same as above (11~12)	Rudder Gauge Max / Min:		(/)
8	Same as above (13~15)	Rudder Left / Middle / Right:		(/ /)
9	Same as above (16~17)	Rudder sensitivity / hydro property :		(/)
10	Same as above (18~20)	Remote Left / Middle / Right:		(/ /)
11	Same as above (21)	Rapid rotation angle:		()
12	Self Test - Compass Adjust Values	Compass X(Min), X(Max) value		(/)
		Compass Y(Min), Y(Max) value		(/)
13	Self Test - Compass Adjust Values	45° revised value: 000° / 045° (000 / 045)		(/)
		45° revised value: 090° / 135° (090 / 135)		(/)
		45° revised value: 180° / 225° (180 / 225)		(/)
		45° revised value: 270° / 315° (270 / 315)		(/)

After installed this SAS-70, the installed man must fill it out.

Chapter 9. Functions of Alert and Trouble indicator

9.1 Alert Function

- ❖ SAS-70 provide information as such out of route, no heading signal, low power voltage alert, waypoint, auto navigate alert etc.
- ❖ On marking "checking mark" in LCD screen, the alert is working and On no marking, the alert is not working.
- ❖ This function works under electric compass / chart plotter based auto steering mode, but under manual and remote mode, this function will be disabled.

9.2 Remote Alert Function for adjustment

- ❖ Under electric compass / chart plotter operation based steering mode, if turns the control knob more than 5 degrees away from neutral, the alarm beeps.

9.3 Function for indicating troubles (Operate Error)

- ❖ SAS-70 has function to check if the unit has errors. During operation, the alert takes place and marks it in a display if the unit has errors.
- ❖ When the alert is ringing, press **ESC** button to stop the sound and it is rechecking.
- ❖ If it has errors, delete the reason of errors and make to operate it again. (If you don't delete the defective reason and you operate it continuously, it can be made more serious errors for over capacity of oil pressure.
- ❖ The types of errors and the contents are as follows.

ERRORS	TROUBLESHOOTING	CONDITIONS
Rudder Error	Malfunctioning on Rudder For solution, please check the solenoid valve or angle sensor	Remote, Compass, Plotter
Compass Error	Malfunctioning on Compass For solution, please check out the compass connection	Manual, Remote, Compass, Plotter
Plotter Error	Connection problem with chart plotter For solution, please check the connection status of plotter	Plotter

- ❖ Status of LED at controller of SAS-70C

LED	STATUS	FUNCTION
POWER	Green	Meaning that it is well working
	Green / Red (on/off)	Meaning that tele-error of CAN, compass error and so on
VALVE	Green	Meaning that the solenoid valve is working to left direction
	Red	Meaning that the solenoid valve is working to right direction

SM-975A ELECTRONIC LEVER

INSTRUCTION MANUAL

<Optional items for this SAS-70>

Chapter 1. Preview

1.1 Engine Control (SM-975A)

An engine related equipment controlling vessels` speed and forward/ backward clutch among vessel automation equipment that is provided by Korean domestic technology of SAMYUNG ENC CO., LTD. SM-975 can be used independently and controlled by remote control. Further, it can be connected with Samyung Auto Steering controller (SAS-70) and GPS chart plotter (Samyung NAVIS series) so that automatic navigation and fishing can be possible.

Since SM-975 controls vessels` engine, safety has been considering of a top priority when it is designed and it works automatically to be secured from wrong operation of user Use of SM-975 is simple and it can be used at DC 20v to DC 40v (24v is recommended for rated voltage). It consists of electronic lever, which is for actuating lever and remote controls that is for controlling lever.

1.2 Product Specification

- ❖ Power supply : DC 20v ~ DC 40v (below 85W)
- ❖ Operating temperature : - 15°c ~ +55°c
- ❖ Lever actuation output power : Speed control lever (governor) 48Kg/226Cm(1min)
Clutch control lever 28Kg/381Cm(1min)
- ❖ Dimension : Main unit(Electronic lever) width(264mm), height(342mm), depth(258mm)
Spot for installation (height 500mm)
- ❖ Weight : Main unit(Electronic lever) 18.5 Kg
Remote controller 2.2Kg (cable included)

1.3 Cautions for operation

- ❖ Check whether the manual governor controller is rocked or not, before turn it on Turn it on after being off the rock
- ❖ If there happens thunder lightning, dont try to touch the metal part of the power switch. There is danger of electronic shock by lightning strikes.
- ❖ Only from DC 20v to DC 40v power is acceptable. If it is connected to A.C power or not provided place, it could cause a fire, a electronic shocks or breakdown of device.
- ❖ Only permitted fuse is acceptable for steering device. In case of replacement, Use only specified fuse, otherwise it cause fire or malfunction of the equipment.
- ❖ Don't treat the cable forcefully. Damaged cable could be a cause of a fire or electronic shock.
- ❖ Don't operate it in case of bad range of vision like in the harbor tiny water way, near at

- obstacles. Unexpected electronic trouble could cause a collision.
- ❖ Full attention required around ship and a course Unexpected trouble could cause a collision.
 - ❖ In case of emergency, please be noted how to change automatic operating mode to manual operating mode.
 - ❖ Keep away from water, the main unit is not perfectly waterproof. otherwise it could be a cause of fire or electronic shock. When the unit get wet, turn off power supply and input power switch and then It should be checked by authorized engineer.
 - ❖ Don't turn on the engine starter after power on. It can make a rapid change of voltage and cause improper operation.

1.4 Terms and abbreviation

1.4.1 Terms Explanation

Terms as like the follows are used in this instruction manual and the other terms are comply with general terms.

- ❖ Engine control unit: It is electronic lever ,which controls RPM of engine ,forward/back and neutral switching gear.
- ❖ Governor(lever): It is a lever that controls engine speed and called as srotle or accelerator
- ❖ Clutch(lever): It is mounted between engine and propeller on ship`s engine system. Ship`s forward/back and neutral can be selected with it.
- ❖ Manual lever: It is a control handle for controlling the RPM of engine and Ship`s forward/back and neutral. It is generally consist of separate Clutch and Governor called two-lever style which is operating by manually
- ❖ Control cable: It is generally called pushable cable that connects governor and clutch of engine with manual lever which is also connected with electronic lever through the cable

1.4.2 Abbreviation Explanation

The colors of wires are described as following.

Single color			
Color number	English	English abbr.	Remarks
0 or 10	Black	Bc	
1	Brown	Br	
2	Red	R	
3	Orange	O	
4	Yellow	Y	
5	Green	Gr	
6	Blue	Bl	
7	Violet	V	
8	Gray	Gy	
9	White	W	
Two colors			
59	Green/White	Gr/W	White line on a green ground

Chapter 2. System Installation

2.1 Installation of Control Cables

Configuration of link cables for engine governor and clutch is as follow picture.

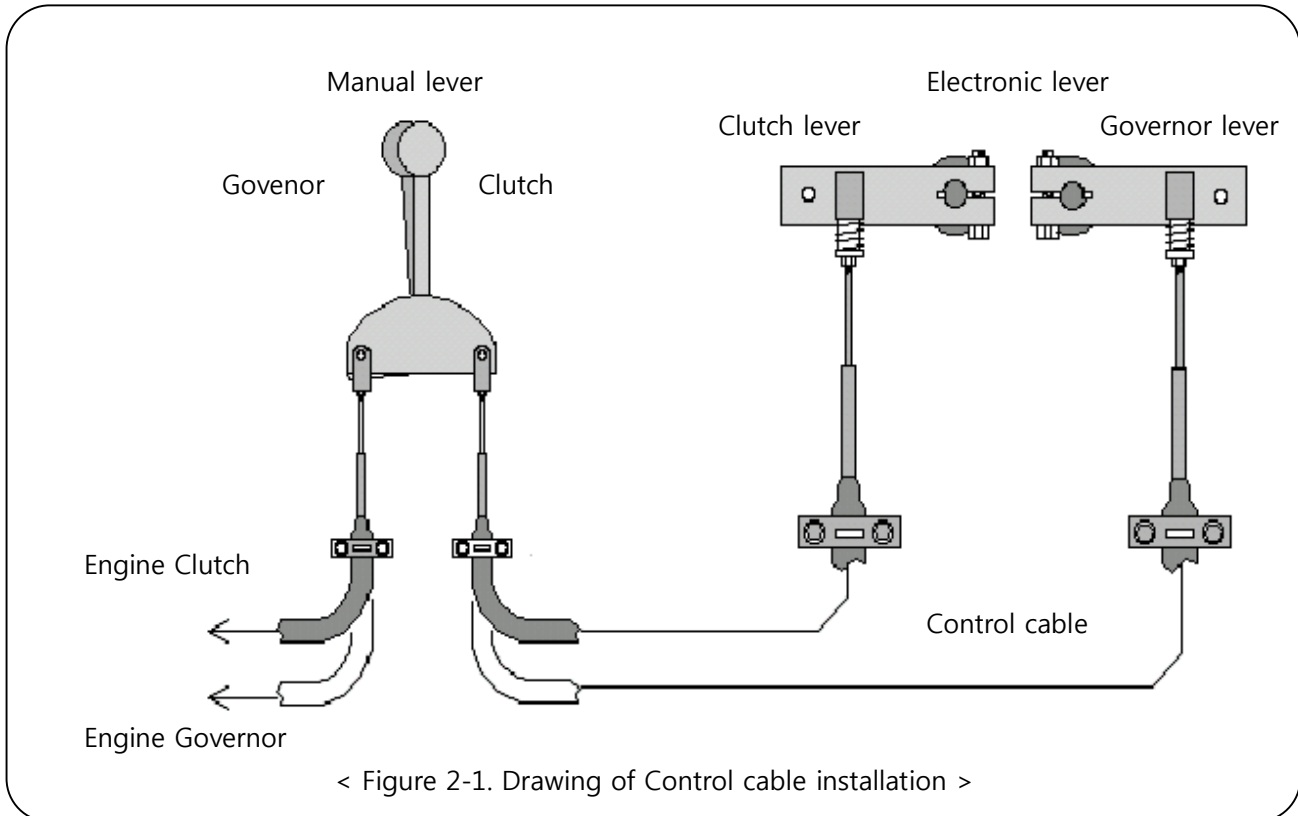

- ❖ It should not be installed at the place with heavy vibration, high temperature and exposed to rainwater or sea water.
- ❖ The diameter of control cable has to be less than 50Cm and has not to be installed as being bent.
- ❖ When the engine is connected to manual lever and manual lever to electronic lever through the cable, the above connections has to be done without backlash

[WARNING] Governor can not be controlled minutely if there is too much backlash on the connections

- ❖ Either switching to forward / maximum speed position by pulling control cable or by pushing the control cable which is connected to electronic lever, there will be no problems of operating. So control cable can be connected as above picture.

[WARNING] Initial setting that switching to forward / maximum speed position by pulling the control cable should be done after installation

2.2 How to connect Control cables

Electronic lever should be installed at a place where the under 50Cm diameter– control cable can be connected to manual lever without bending the control cable.

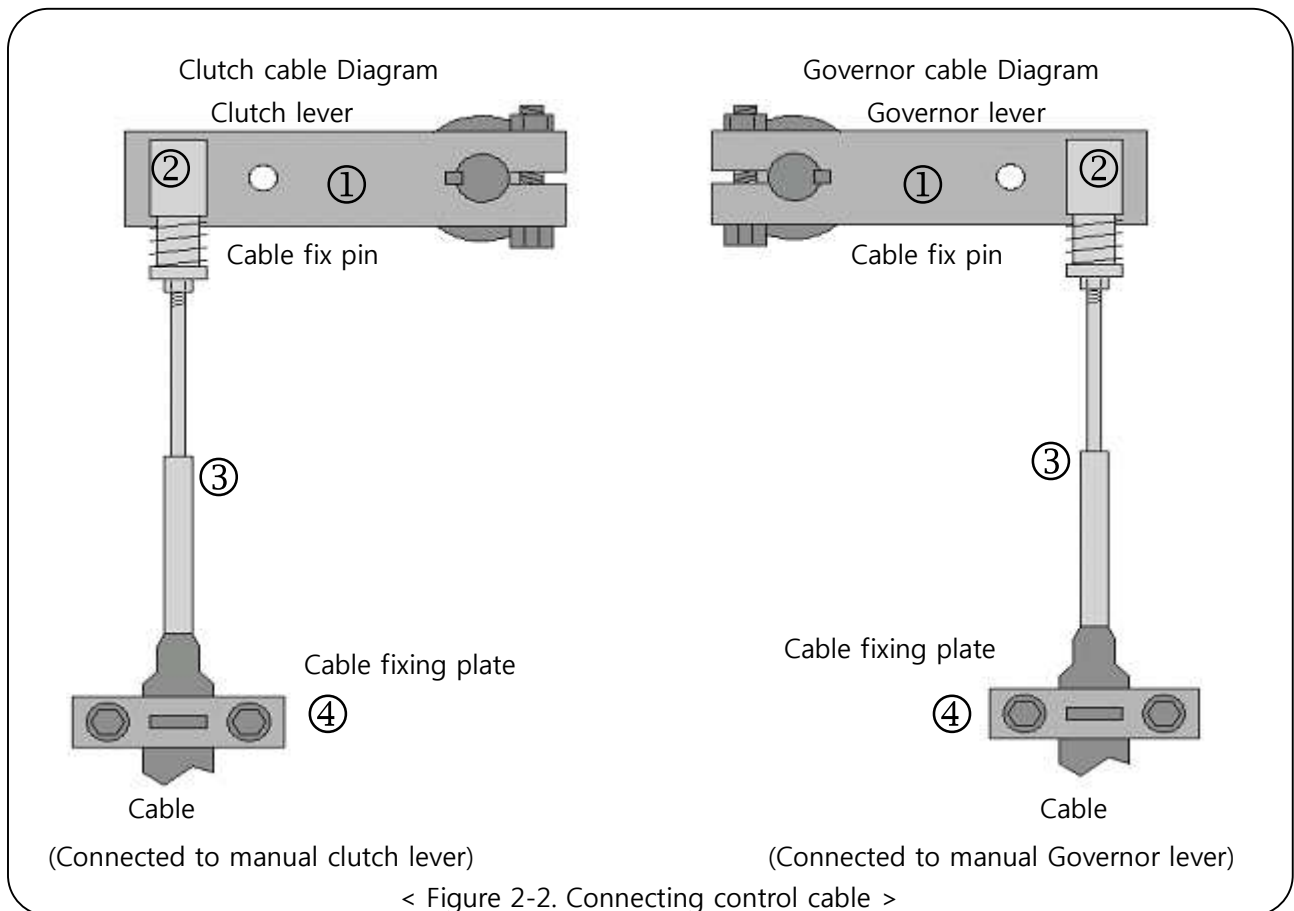

- ❖ When open the lid of electronic lever, you will see two levers as above picture. The left one is clutch lever and the right one is governor lever.
- ❖ When dismantle the manual lever, you will see the control cables that are connected to engine clutch and governor. There is also another connection points on manual lever for control cables that can be connected to electronic lever. (control cable will be along with main unit when it is released)
- ❖ After assembling the manual lever, put the clutch and the governor of manual lever on middle point of the lever.
- ❖ Mount a cable link-pin "②" on the end of control cable that is connected to manual and tighten up a screw.
- ❖ Put the levers "①" on middle point and connect the clutch cable and governor cable to the levers respectively. (connect "①" with "②" in the above picture.)
- ❖ Fix the cable through the cable fixing plate"④"
- ❖ Check whether the electronic lever is working properly according to the motions of the clutch and governor lever.
- ❖ Mount a cable fixing pin on the outside of electronic lever as the below picture If there is any difference between moving space of manual lever and electronic lever.

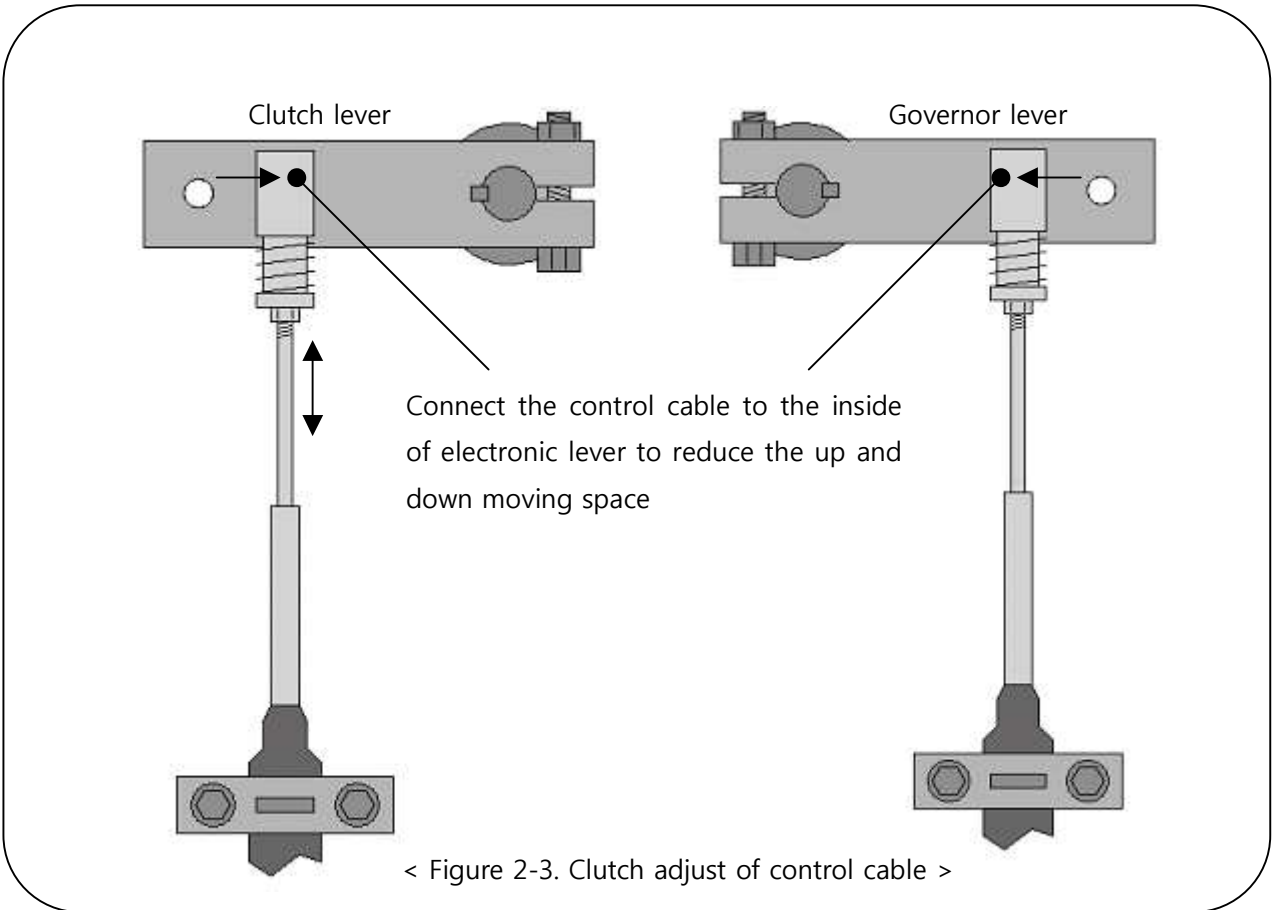

2.3 Cable connection to manual lever

Check the installed manual lever first to ensure highest performance when it is connected with electronic lever through the control cable.

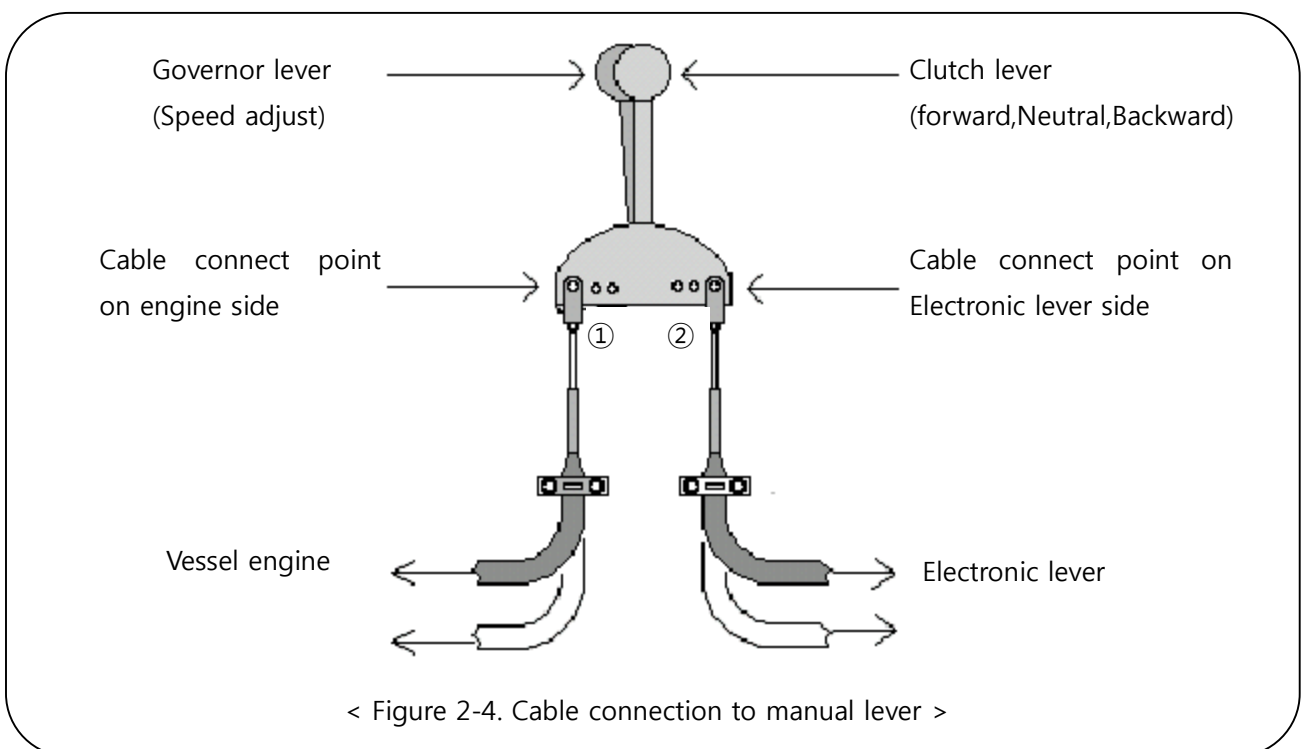

- ❖ For best performance of motion of manual clutch lever , link point of "①" on above picture should be selected properly.
 - a) When the manual clutch lever is on forward position, location of the lever has to be forwarded by pushing it.
 - b) b) When the manual clutch lever is on neutral position, location of the lever has to be in the middle.
 - c) c) When the manual clutch lever is on reverse position, location of the lever has to be backed by pulling it.
- ❖ For best performance of motion of manual governor lever , link point of "①" on above picture should be selected properly.
 - a) When maximum speed, location of the lever has to be forwarded by pushing it.
 - b) When minimum speed, location of the lever has to be backed by pulling it
- ❖ Position adjustment of manual lever can be done by selecting a link point of "①" and minute adjustment can be done by turning the linking device of the control cable
- ❖ Cable link point of the electronic lever side has to be same as able link point of the engine side.

2.4 Wiring Connection

Please observe the follow instruction before electric wiring. If fail to meet this instruction, electric shock or damage of equipment can occur.

- ❖ Power should be off.
- ❖ Check the terminal plate (+ , -) of main unit and don't connect it reversely.
 - ☞ polarity : white colour -> [+] , black colour -> [-]

[Caution] If power is on when the connection of polarity is reverse , fuse will be broken and if the installed fuse was not a standard one , it could cause a damage on the unit.

- ❖ Check terminal mark and wire colour first and then fix screws in case of the connection of junction terminal. ☞ wrong connection could cause a damage on the unit
- ❖ Check whether there is any contact among terminals after completing electric wiring
- ❖ Cable shield, which is connected to remote control or auto steering controller has to be connected to terminal "C" of electronic lever.
- ❖ Cut it out in proper length when a cable is longer than needed. Use same kind of cable when a cable is shorter than needed.
- ❖ Install "power switch" at a place where is easy to access. ☞ recommendable place is near the manual lever because it is necessary to switch on/off for converting of manual control or Remote control .
- ❖ Install the unit away from radio transceivers such as SSB, VHF radio.
- ❖ ☞ Keep away electric wiring of engine control from electric wiring of radio transceivers
- ❖ It is because the operating of unit can be interfered by radio transceivers

2.5 Drawing for wiring connection (Connected to Auto Pilot)

- ❖ In case of electronic lever (engine control unit) installation with auto steering controller (SAS-7), the way of electric wiring follows as the below picture.
- ❖ Remote control shall be connected to terminal plate of auto steering controller (SAS-7).
- ❖ Use the supplied cable that will come along with units for connection of electronic lever and auto steering controller. If user wants to select cable by himself, shield cable has to be used.
- ❖ When even the electric wiring of power input is connected to auto steering controller, separate power switch is necessary.
- ❖ RX and TX wiring among the electric wirings, which is connected to auto steering controller has to be connected with reverse. It means that RX terminal of electronic lever should be connected to TX terminal on terminal plate of auto steering controller and vice versa.

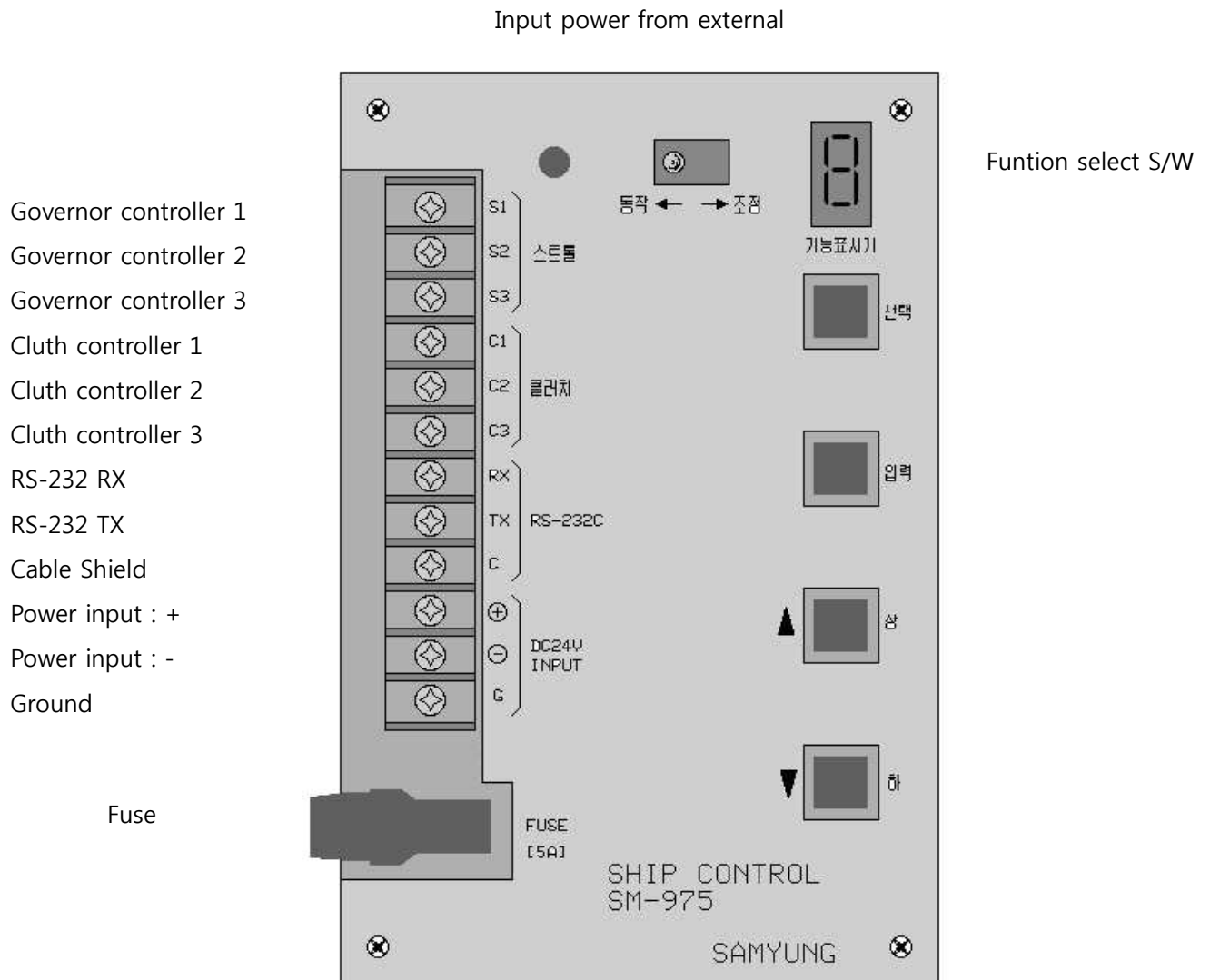

< Figure 2-5. Connection drawing for electronic lever >

2.6 Drawing for wiring connection (Electronic lever separate type)

- ❖ In case installing this electronic lever separately, the drawing is as followings.
- ❖ In installing with single type, the relative wiring for auto pilot is not used among cables of remote controller.

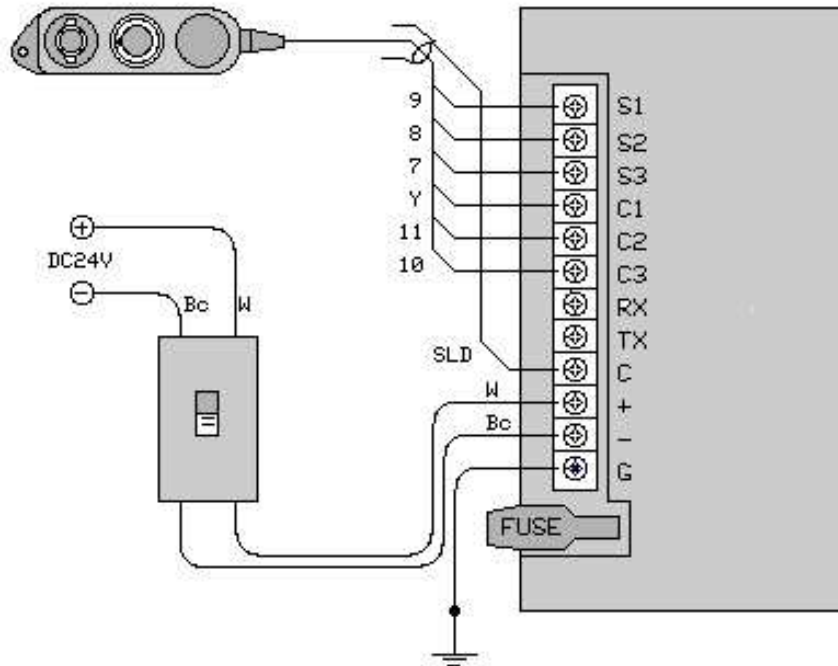

< Figure 2-6. Single electronic lever >



2.7 Cautions in initial power-on

Please check the below terms for initial power inputting.

- ❖ Check whether the control cable is installed properly or not.
- ❖ Check whether the voltage of battery is 24v (rated voltage) or not.
- ❖ Check whether the engine is being off or not.
- ❖ Check whether the clutch of manual lever is set as neutral and governor of manual lever is set as minimum speed or not.
- ❖ Check whether the clutch and governor location of remote control is same as manual lever's clutch and governor location
- ❖ Check whether the governor controller's lock of manual lever is unlocked and, if not, unlock it.
- ❖ Don't turn on the engine starter after power on. It can make a rapid change of voltage and cause improper operation.
- ❖ Once the unit is powered on, it will work normally after an instant buzzing. But if the clutch and governor location of remote control is different from manual lever's clutch and governor location, the buzz will going on and remote control won't work until the clutch and governor location of remote control and manual lever become same.
- ❖ Do the initial setting after checking all the installed devices through watching and hearing the devices.

Chapter 3. Initial setup after installation

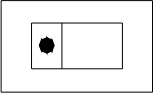
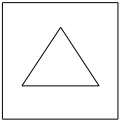
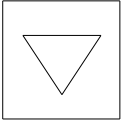
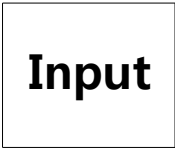
3.1 Controller for initial setup

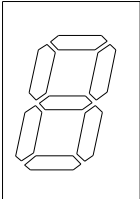
button	Function	Operation	
	Working/Setup	As the initial set switch is used for wiring operation. After completing all installation, set switch to [set] position and control clutch lever, governor lever, clutch sensitivity, governor sensitivity. After initial set, you should set [operation] position. You should power on with [switch] position, it will operate as set condition.	
	Upper	<p>When the initial set is operated, lever and sensitivity controller are as follows.</p> <ol style="list-style-type: none"> 1. As numbers of FND indicator are one of 1,2,3,4,5,6 it is moved to pulled fushcable while this switch is pressed. 2. As FND indicator number is 7, governor sensitivity is increased. 3. AS FND indicator number is 8, clutch sensitivity is increased. 	
	low	<p>When the initial set is operated, lever and sensitivity controller are as follows.</p> <ol style="list-style-type: none"> 1. As numbers of FND indicator are one of 1,2,3,4,5,6 it is moved to pulled fushcable while this switch is pressed. 2. As FND indicator number is 7, governor sensitivity is increased. 3. AS FND indicator number is 8, clutch sensitivity is increased 	
	Choice	As the initial set is operated, chosen switch is displayed on FND, whenever putting button, 1~8 numbers are displayed in order.	
	Input	This switch is to memory set value at each set item when the initial set is operated. It is described that the moment of pressed control condition is stored and operates as stored condition at normal operation.	
	FND	As the initial set is operated, chosen item is displayed 1~9 each number set item is as follows. 0 : Normal Operation	
		Set Operation(Set + Power ON)	Set Function(Set + Choice + PowerON)
		<ol style="list-style-type: none"> 1 : Governor full speed set 2 : Governor slow speed set 3 : Clutch forward position set 4 : Neutral position set before clutch 5 : Clutch astern position set 6 : Neutral position set after set 7 : Governor sensitivity control 8 : Clutch sensitivity control 9 : Standard value set (On delivering, set value) 	1 : Governor automatic scope set

3.2 Operating setup (Setup + Power ON)

- ❖ With ship's engine is off, check all electric wire, portable transmitters wire and fushble cable locking condition, set operation/set switch [set] position.
- ❖ Main power supply switch (install outside of unit) ON, supplies power.

[Caution] As lover position is set to control lever with press switch, pay attention to not go over top and bottom control scope.

[Caution] As all control is completed, notice Operation position.

[Caution] After the initial set, follow normal action and be sure to check that engine-off after all action test.

- ❖ Governor Full position speed set
 - ① Check if operation/set switch is [set].
 - ② Press choice switch to set 1 on indicator
 - ③ Set Governor controller of remote controller to set [FULL] position.
 - ④ Press ▲ switch or ▼ switch to control Governor lever of Control lever(manual controller) to be [FULL]speed position.
 - ⑤ Press Input switch
 - ⑥ In case of not the initial set, set operation/set switch to [operation]. Indicator would be displayed 0 at normal operation.

[Caution] Notice if fushble cable is too tightly pulled.

- ❖ **Governor slow speed position set.**
 - ① Check if operation/set switch is set [set].
 - ② Press choice switch to set 2 on indicator
 - ③ Set Governor controller of remote controller to set [SLOW] position.
 - ④ Press ▲ switch or ▼ switch to control Governor lever of Control lever(manual controller) to be [SLOW]speed position.
 - ⑤ Press Input switch
 - ⑥ In case of not the initial set, set operation/set switch to [operation]. Indicator would be displayed 0 at normal operation.

[Caution] Notice if fushble cable is too tightly pulled.

- ❖ **Clutch AHEAD position set.**
 - ① Check if operation/set switch is set [set].
 - ② Press choice switch to set 3 on indicator
 - ③ Set Governor controller of remote controller to set [AHEAD] position.

- ④ Press ▲ switch or ▼ switch to control Clutch lever of Control lever(manual controller) to be [AHEAD]position.
- ⑤ Press Input switch
- ⑥ In case of not the initial set, set operation/set switch to [operation]. Indicator would be displayed 0 at normal operation.

[Caution] Notice if fushble cable is too tightly pulled.

❖ **Clutch ahead neutral position set.**

- ① Check if operation/set switch is [set] mode.
- ② Press choice switch to set 4 on indicator.
- ③ Set clutch controller of remote controller to [N] position.
- ④ Press ▲ switch or ▼ switch to control Clutch lever of Control lever(manual controller) to be [ASTERN]speed position.
- ⑤ Press ▲ switch or ▼ switch to control Clutch lever of Control lever(manual controller) to be [N]speed position.
- ⑥ Press Input switch
- ⑦ In case of not the initial set, set operation/set switch to [operation]. Indicator would be displayed 0 at normal operation.

[REF] According to ships condition (caused by backlash), it is distinguished control condition between ASTERN to NEUTRAL and AHEAD to NEUTRAL, then set separately AHEAD NEUTRAL or ASTERN NEUTRAL.

❖ **Clutch ASTERN position set.**

- ① Check if operation/set switch is [set] mode.
- ② Press choice switch to set 5 on indicator.
- ③ Set clutch controller of remote controller to [ASTERN] position.
- ④ Press ▲ switch or ▼ switch to control Clutch lever of Control lever(manual controller) to be [ASTERN]speed position.
- ⑤ Press Input switch
- ⑥ In case of not the initial set, set operation/set switch to [operation]. indicator would be displayed 0 at normal operation.

[Caution] Notice if fushble cable is too tightly pulled.

❖ **Clutch ASTERN NEUTRAL position set.**

- ① Check if operation/set switch is [set] mode.
- ② Press choice switch to set 6 on indicator.

- ③ Set clutch controller of remote controller to [N] position.
- ④ Press ▲ switch or ▼ switch to control Clutch lever of Control lever(manual controller) to be [ASTERN]speed position.
- ⑤ Press ▲ switch or ▼ switch to control Clutch lever of Control lever(manual controller) to be [N]speed position.
- ⑥ Press Input switch
- ⑦ In case of not the initial set, set operation/set switch to [operation]. Indicator would be displayed 0 at normal operation.

[REF] According to ships condition (caused by backlash), it is distinguished control condition between ASTERN to NEUTRAL and AHEAD to NEUTRAL, then set separately AHEAD NEUTRAL or ASTERN NEUTRAL.

❖ **Governor sensitivity set.**

[Caution] Governor sensitivity control is required to following process such as, [1 Governor FULL position set], [2 Governor SLOW position set], [3 Clutch AHEAD position set], [4 Clutch AHEAD N position set], [5 Clutch ASTERN position set], [6, Clutch ASTERN N position set],

- ① Check if operation/set switch is [set] mode.
- ② Press choice switch to set 6 on indicator.
- ③ Sensitivity control by ▲ switch (increase sensitivity, indicator number is increased) or ▼ switch (decrease sensitivity, indicator number is decreased). This is the best suited set on delivery, then other control doesn't need but in case of necessary, the following order is controlled. (Sensitivity control is feasible 1 to 5)
 - A. At normal movement governor controller of remote controller is in no motion, governor lever is coming and going to decrease sensitivity.
 - B. The more governor controller of remote controller move a lot the more governor lever move. If it is less move and governor lever is no movement, set sensitivity high.
- ④ Above [3] item control is over, press Input switch.
- ⑤ In case of not the initial set, set operation/set switch to [operation] Indicator would be displayed 0 at normal operation. [5] In case of not the initial set, set operation/set switch to [operation] Indicator would be displayed 0 at normal operation.

❖ **Clutch sensitivity set**

[Caution] Clutch sensitivity control is required to following process such as, [1 Governor FULL position set], [2 Governor SLOW position set], [3 Clutch AHEAD position set], [4 Clutch AHEAD N position set], [5 Clutch ASTERN position set], [6, Clutch ASTERN N position set],

- ① Check if operation/set switch is [set] mode.
- ② Press choice switch to set 6 on indicator.
- ③ Sensitivity control by ▲ switch (increase sensitivity, indicator number is increased) or ▼ switch (decrease sensitivity, indicator number is decreased). This is the best suited set on delivery, then other control doesn't need but in case of necessary, the following order is controlled. (Sensitivity control is feasible 1 to 5)
 - A. Clutch lever is coming and going to decrease sensitivity.
 - B. The more clutch controller of remote controller move a lot the more clutch lever move. If it is less move and clutch lever is no movement, set sensitivity high.
- ④ Above [3] item control is over, press Input switch.
- ⑤ In case of not the initial set, set operation/set switch to [operation]. Indicator would be displayed 0 at normal operation.

- ❖ Standard value set (initialize set value on delivery)

[Caution] Notice all item which is set by user is deleted and initializes as set value on delivery.

- ① Check if operation/set switch is [set] mode.
- ② Press choice switch to set 6 on indicator.
- ③ Press Input switch.
- ④ In case of not the initial set, set operation/set switch to [operation], then indicator would be displayed 0 at normal operation.

3.3 Functional setup (Setup + Select + Power ON)

- ❖ With ship's engine is off, check all electric wire, portable transmitters wire and fushble cable locking condition, set operation/set switch [set] position.
- ❖ With pressed choice switch, switch on power supply switch(install outside of unit) and supply power.
- ❖ Release a hand on pressed choice switch.

[Caution] As all control is completed, make sure that return to [operation] position.

- ❖ **Governor auto scope set.**

Auto scope means governor position is set high and engine is high revolving. If turn clutch controller, governor would be slow and clutch lever is auto-operated at the same level of controller which means to protect engine and clutch.

- ① Press choice switch to set 1 on indicator.
- ② Press ▲ switch or ▼ switch to control governor lever of Control lever(manual controller) to be position where could control clutch (engine revolving speed)
- ③ Press Input switch

- ④ In case of not the initial set, set operation/set switch to [operation]. After power off, switch on after 5 seconds. It would be back to normal operation.

[Caution] As setting with engine start-off, test auto scope by manual lever before set, control balance with revolving speed of engine.

3.4 Default values for operation / functions

Standard value on delivery is as follows,

<Operation Set Initial value>

- 1 Governor full speed position - pull cable to position lever 45°
- 2 Governor low speed position - push cable to position lever 45°
- 3 Clutch ahead position - pull cable to position lever 45°
- 4 Clutch ahead neutral position - pull on the center of cable to position 45°
- 5 Clutch astern position - push cable to position 45°
- 6 Clutch astern neutral position - push on the center of cable to position 45°
- 7 Governor sensitivity – 3
- 8 Clutch sensitivity - 3

<Function Set Initial Value>

- 1 Governor Auto Scope - 10 %

Chapter 4. How to Operate

4.1 Functions for Remote Controller

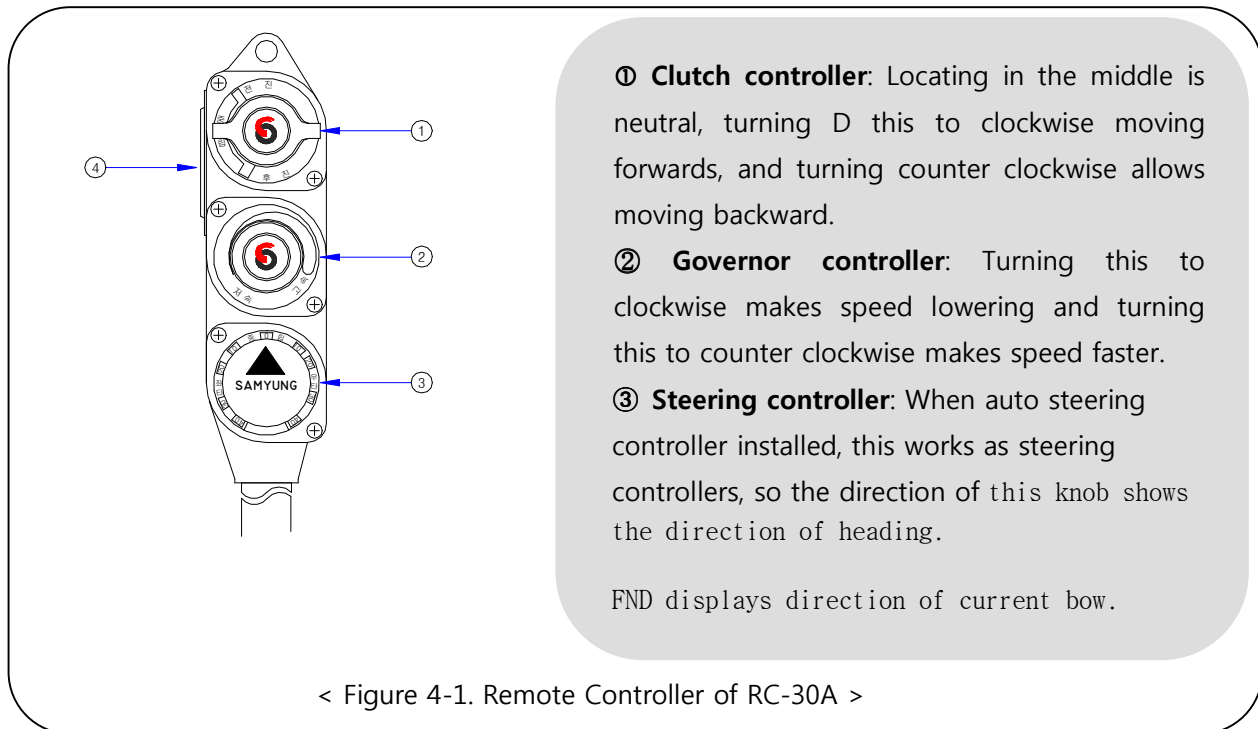

4.2 How to operate for Remote Controller

To remote control engine, first after install it, complete the initial set and function set, the following step should be taken.

- ❖ Check if clutch of remote and position of governor are same level of manual lever.
- ❖ Check if lock device on governor lever of manual lever is released. (If lock device is fastened, it will cause trouble of electric lever.)
- ❖ Switch on power switch of electric lever (separate installed switch).
- ❖ If Buzzing is for 2 seconds and stop, that is normal. Control engine as clutch and governor controller by means of remote controller use.
- ❖ If buzzing is activating constantly above 4 items, check if manual lever and remote controller position are same level. Buzzer would be stepped and operated normally.
- ❖ Clutch controller is operating regardless of revolving speed. Governor controller should be handled slowly due to controller revolving speed affect engine revolving speed.

[Caution] After checking engine revolving speed(auto check), control clutch. If it is more than 10% at low speed, set engine revolving speed to low speed. After 2 seconds, set clutch setting condition.

[Caution] If clutch is AHEAD or ASTERN but NEUTRAL, after that set clutch approximately after 1 second, set engine revolving speed automatically at same level of governor control position of remote control. Approximately, as 10% (Governor slow speed to full speed one-hundredth percentage) is increased at 1 second, full revolving speed is increased at 5 seconds.

However, if you turn governor controller in auto accelerated, it will set current controller position.

[Caution] As using manual control on remote control, power off ,then manual control by manual lever is available.

Power on, compare and check between remote control, governor control position and manual clutch, governor lever position (auto check). If that is differently positioned, buzzer would be ringing. Remote doesn't control in the time of ringing and only geared by manual lever.

(Buzzer would be stopped if it is united and controlled by remote control)

Chapter 5. Drawing for SM-975A

5.1 Outline drawing for Electronic Lever

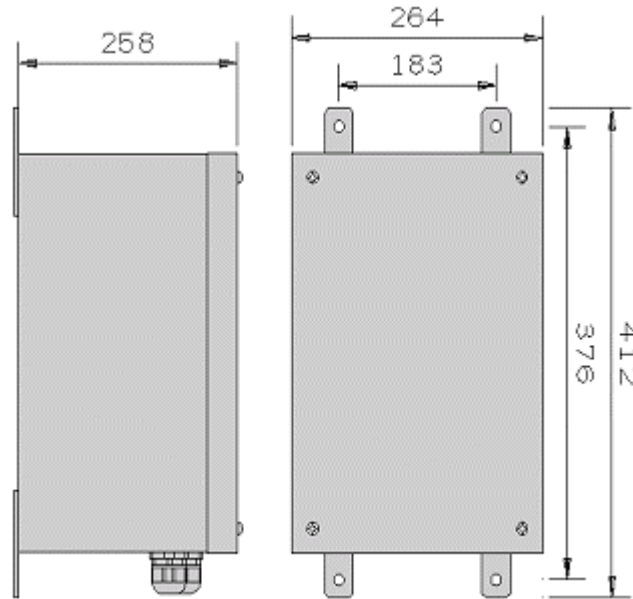

< Figure 5-1. Outline drawing for Electronic Lever >

5.2 Outline drawing for Remote Controller

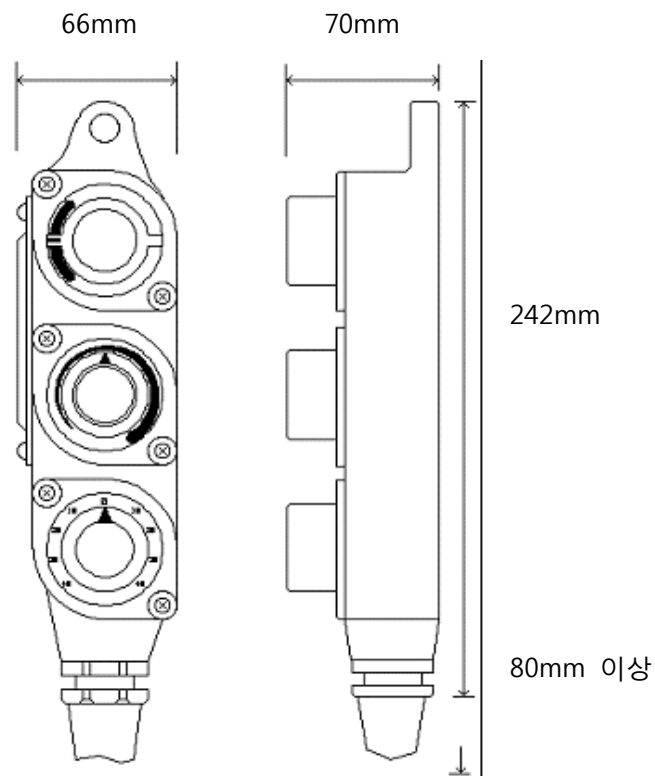

< Figure 5-2. Outline drawing for Remote Controller >

5.3 System Configuration

5.3.1 Configuration for Electronic Lever separate type (SM-975A)

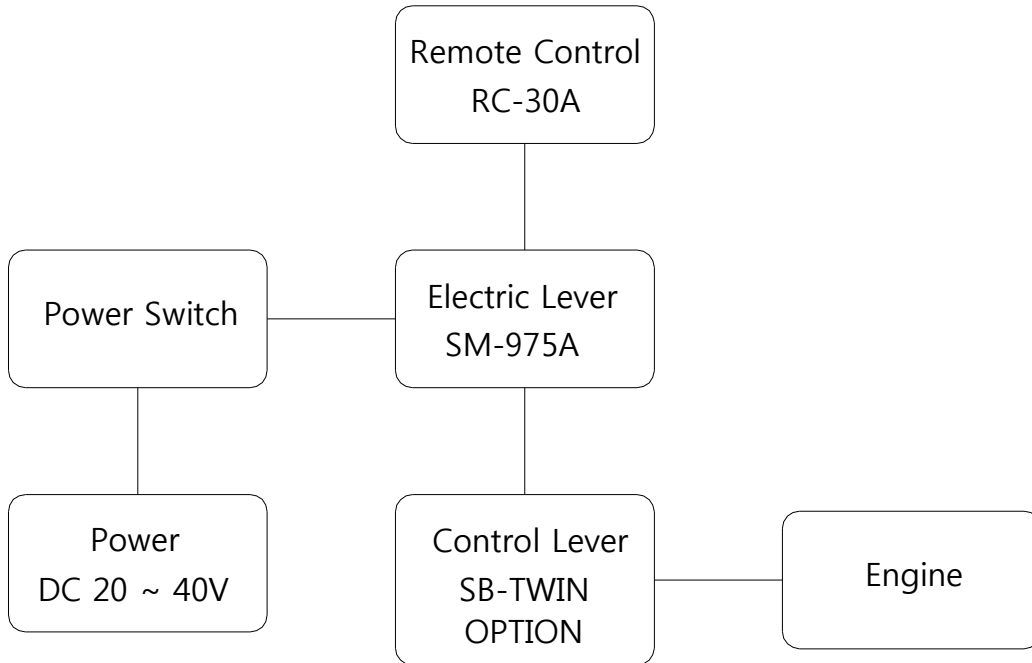

5.3.2 Auto Steering / Electronic Lever (SAS-70+SM-975A)

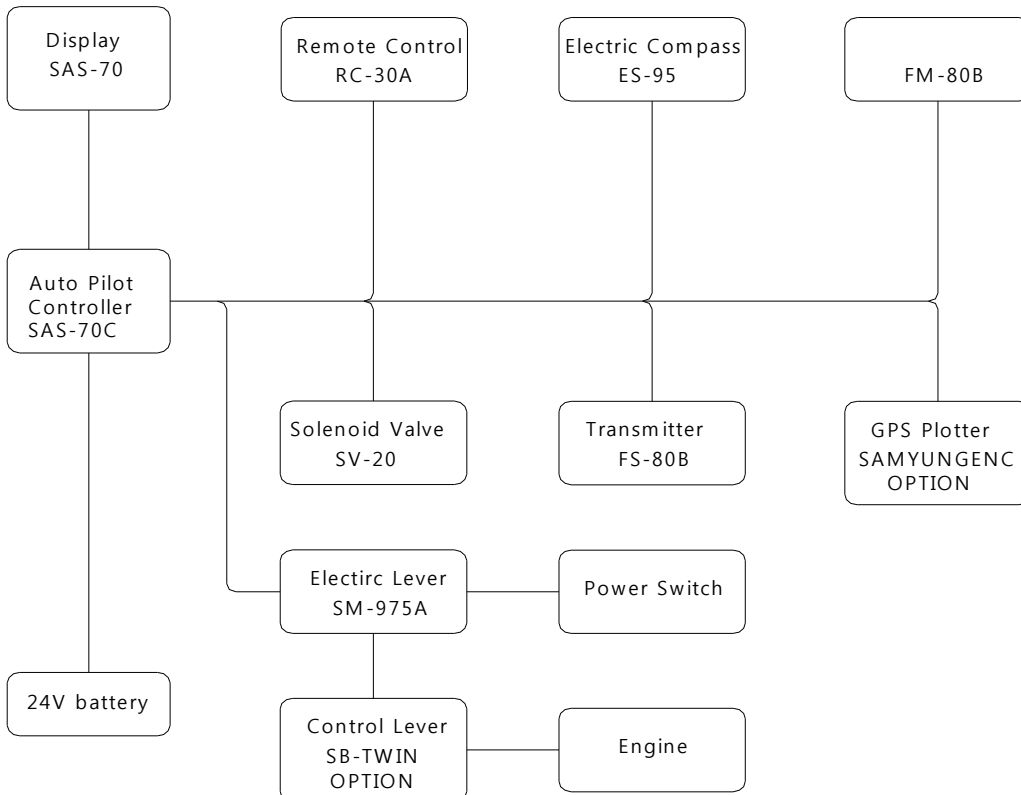

5.4 Connecting diagram for Electronic lever

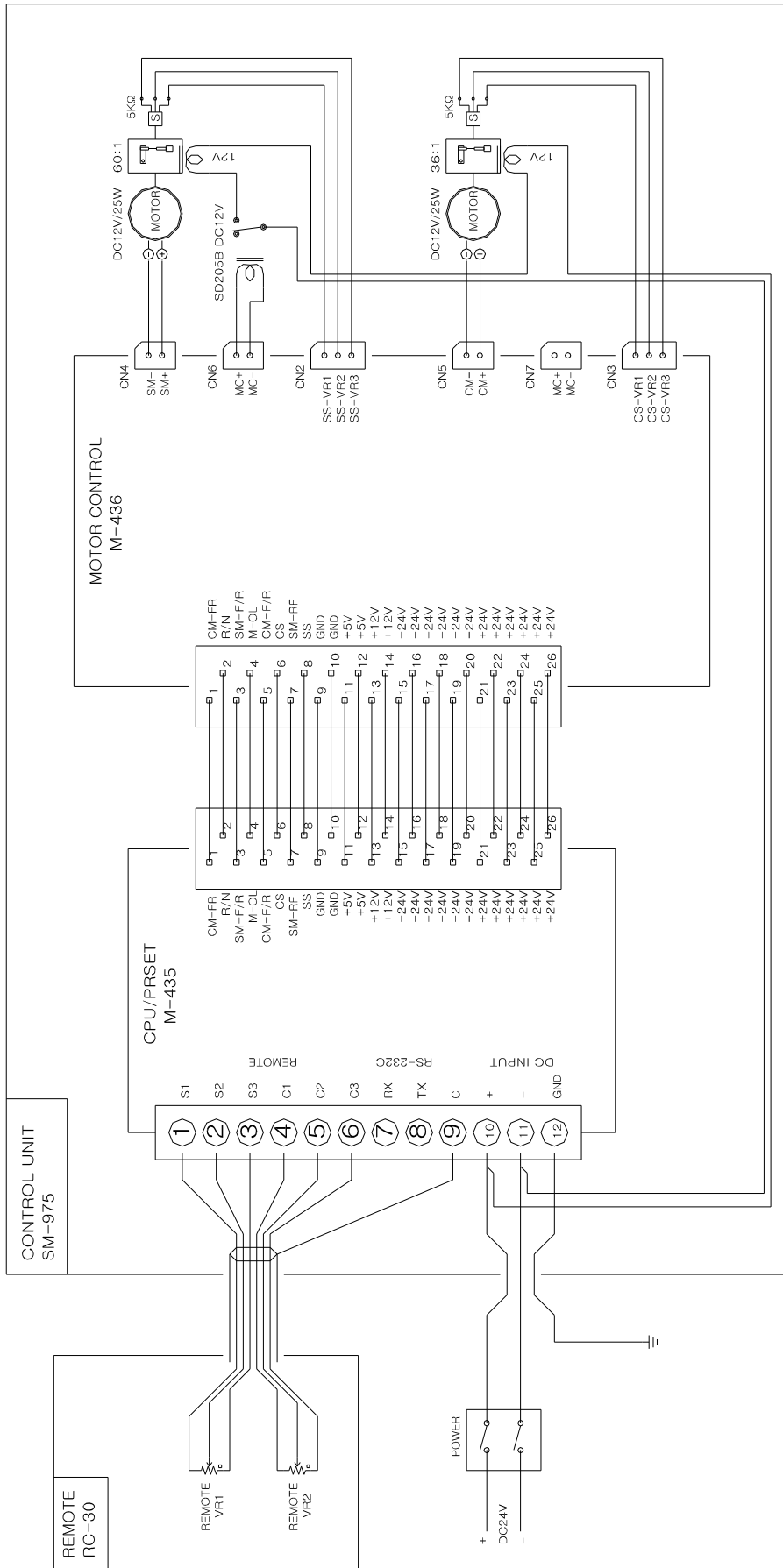

Chapter 6. PACKING LIST

6.1 SAS-70

SAS-70 (1/2)							
NO.	Name of Product	Shape	Specification		QTY	Check	Remark
1	Display unit (Bracket for fix)		SAS-70		1 EA	A-10	
			CODE NO.	SAS-70			
2	Controller		SAS-70C		1 EA		
			CODE NO.	SAS-70C			
3	Remote Adapter		SAS-70A		1 EA	A-08	
			CODE NO.	SAS-70A			
4	Remote controller (Included cable)		RC-10A		1 SET	A-01	4M or 12M (12P shield)
			CODE NO.	SM-5001			
5	Rudder Angle Indicator (Included cable)		FM-80B		1 SET	A-05	5M(0.5mm ² X 4C shield)
			CODE NO.	SM-5052			
6	Electric Compass (Included cable)		ES-95		1 SET	A-04	10M (6P shield)
			CODE NO.	SM-5003			
7	Solenoid, Valve, Fix volt, Nut, Spring Yasa, Yasa (Included cable)		SV-20		1 EA		6 X 30mm 4 SET
			CODE NO.	SM-5004			
8	Transmitter (Included cable)		FS-80B		1 SET	A-02	12M (1.25mm ² X3 shield)
			CODE NO.	SM-5055			
9	Transmitter Connect Device				1 SET		
			CODE NO.	SM-5006			
10	Transmitter board, Fix volt, Nut, Spring Yasa, Yasa		Ø8 X 30mm		4 SET		
			CODE NO.	SM-5007			
11	Solenoid Valve Connect Cable		8M (1.25mm ² X 3C)		1EA	A-06	
			CODE NO.	SM-5008			
12	Power Connect Cable		5M (2.0mm ² X 2C)		1EA	A-07	
			CODE NO.	SM-5059			
13	Remote Cable		5M(24AWG X 7C)		1EA	A-08	
			CODE NO.	SM-5060			
14	Display connecting cable		6M(24AWG X 4C)		1EA	A-10	
			CODE NO.	SM-5061			
15	Plotter connecting cable		6M(20AWG X 2C)		1EA	A-03	
			CODE NO.	SM-5062			
16	Ground cable		3M (KIV 5.5mm ²)		1EA	A-11	
			CODE NO.	SM-5063			

SAS-70 (2/2)						
NO	Name of Product	Shape	Specification	QY	Check	Remark
17	1 type stand fix		Ø4 X 16mm(반달 머리)	20		
			CODE NO. SM-5064	EA		
18	1 type stand fix		Ø3 X 16m(반달 머리)	4EA		SAS-70C Fixing
			CODE NO. SM-5065			
19	PLUG		MSTB 2.5/8-STF	3EA		Terminal Plug
			CODE NO. SM-5066			
20	Cable Housing		KGG-MSTB 2.5/8	3EA		Terminal Case (Stickers)
			CODE NO. SM-5067			
21	Power Fuse		3A (20mm)	2		
			CODE NO. SM-5068	EA		
22	Power Fuse		10A (20mm)	2		
			CODE NO. SM-5014	EA		
23	PVC band		DACT-300	30		300mm
			CODE NO. SM-5015	EA		
24	Brake switch		30A	1	A-07	
			CODE NO. SM-5017	EA		
25	Fix fierce for brake switch		Ø4 X 30mm	2		
			CODE NO. SM-5018	EA		
26	Saddle		4N, 5N, 6N	각		
			CODE NO. SM-5019	10EA		
27	Hydro Hose 1/2 X 1W		1.5M	3		
			CODE NO. SM-5020	EA		
28	Hydro Hose 1/2 X 1W		1M	1		
			CODE NO. SM-5021	EA		
29	Hydro Hose 1/2 X 1W		0.6M	4		
			CODE NO. SM-5022	EA		
30	Forged Screw Tie		1/2	3		
			CODE NO. SM-5023	EA		
31	Steel Nipple		1/2	4		
			CODE NO. SM-5024	EA		
32	Hose Connect Nipple		1/2	3		
			CODE NO. SM-5025	EA		
33	Steel Nipple (elbow type)		1/2	3		
			CODE NO. SM-5026	EA		
34	Instruction manual		SAS-70-MK	1		
			CODE NO. SM-5028	EA		

6.2 SAS-70 OPTION(In case of additional SM-975A)

SM-975A (1/1)						
NO.	Name of Product	Shape	Specification	QY	Check	Remark
1	Electric Lever		SM-975A	1EA	A-09	
			CODE NO. SM-5029			
2	Remote Control		RC-30A	1EA	A-01	
			CODE NO. SM-5030			
3	Control cable		2.4m or 3m	1EA		
			CODE NO. SM-5031			
4	Electric Lever Installation part		Refer to below	1SET		
			CODE NO.			
4-1	Stain fix volt		5 X 20 1 type	5EA		
			CODE NO. SM-5032			
4-2	Fuse		5A (20mm)	2EA		
			CODE NO. SM-5033			
4-3	FushbleCable Terminal			2EA		
			CODE NO. SM-5034			
4-4	Fushble Cable Terminal Pin			2EA		
			CODE NO. SM-5035			
4-5	Fushble Calbe Band			2EA		
			CODE NO. SM-5036			
4-6	Fushble Cable Band Support			2EA		
			CODE NO. SM-5037			
4-7	Stain Fix volt		4 X 30 1종	2EA		
			CODE NO. SM-5038			
4-8	Volt		5 X 10 일반	4EA		
			CODE NO. SM-5039			
4-9	Brake Switch		15A	1EA		
			CODE NO. SM-5040			
4-10	Caution sticker			1EA		
			CODE NO. SM-5041			

Chapter 7. PRODUCTS DRAWINGS

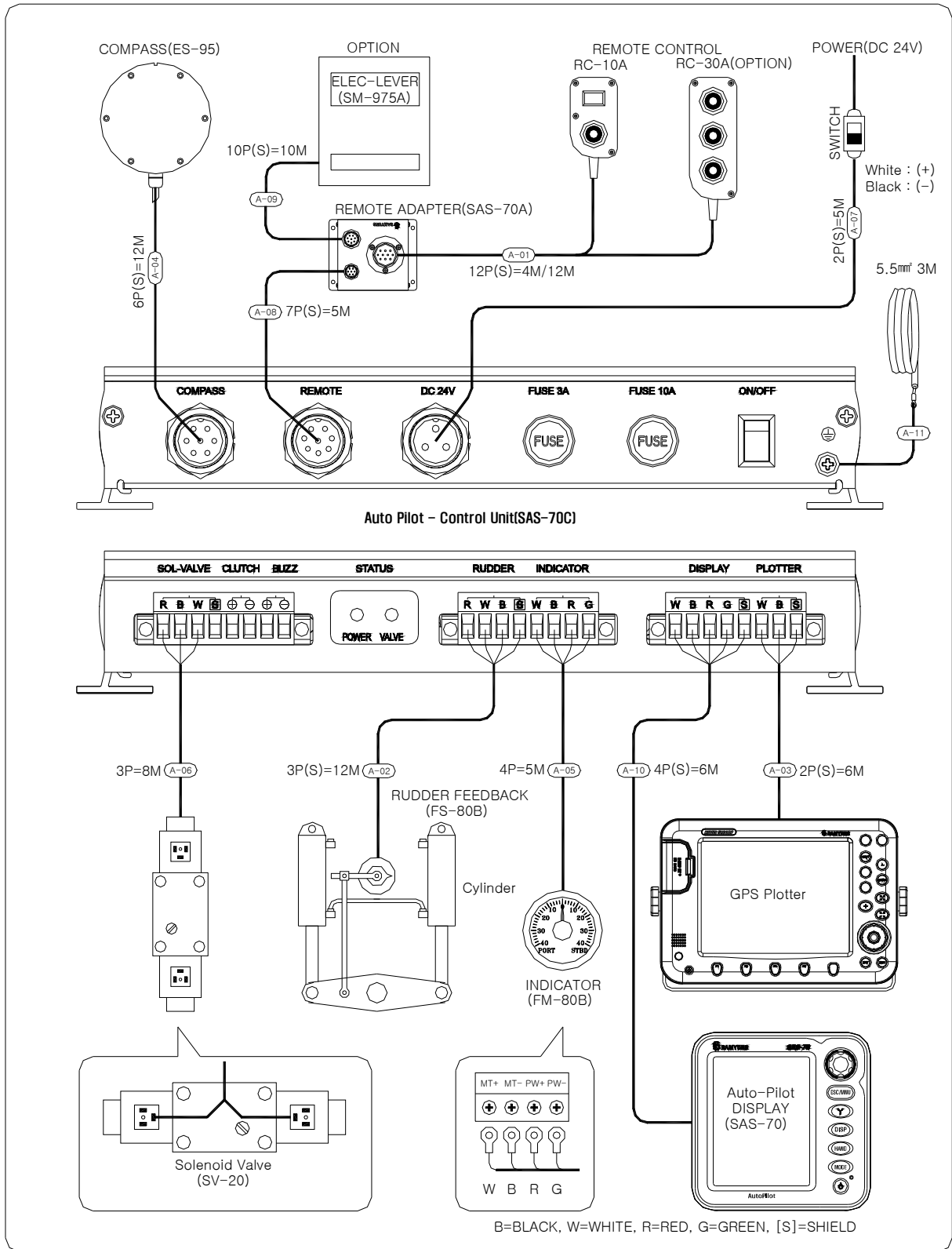

Connect "black" and "white" of solenoid valve in reverse in case of operation of the rudder
 Connect "red" and "white" of transmitter in reverse in case of operation of the Rudder Angle Indicator

00-0006-003 ON

Revision History					
No.	Loc.	Description	Modifier	Approval	Date

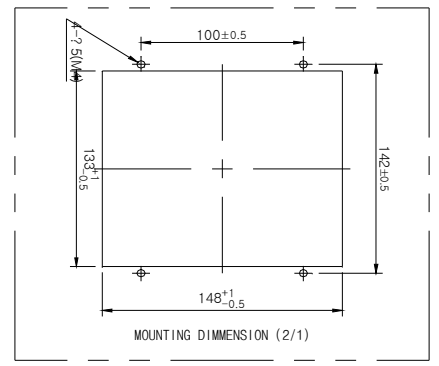
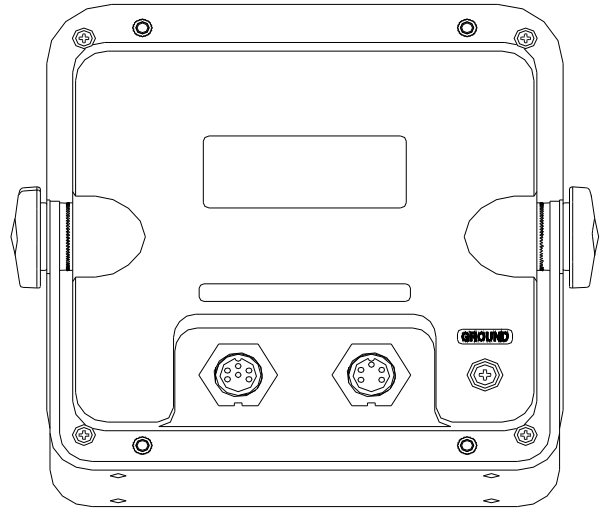
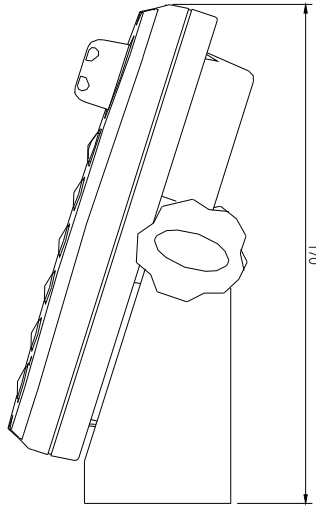
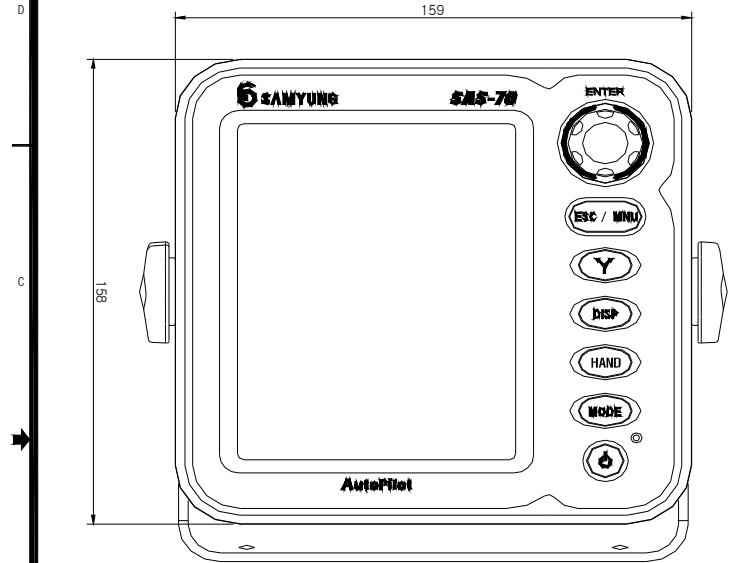

Substitute		No.	Part Name	Q'ty	PART No.	Remark
Original Drawing		Date		02/15/2008		
General Tolerance		Decimal		Angle		Fraction
±0.2		±1.0°		-		
Material		Approved		R&D		
SAS-70		Checked		B.H KANG		
Heat treatment		Designed		B.H KANG		
Ref. Drawing	Adoption Item	Q'ty		1 EA/SET		
Part No.	Stock No.	Finish		-		
Scale 1:1		Unit	mm	Wt	kg	
List of component				TITLE		
SAMYUNG ENC				SAS-70		
Size A2				DWG No. E00-9000-00		
1				of 1		

10-0006-00E No.

Revision History					
No.	Loc.	Description	Modifier	Approval	Date

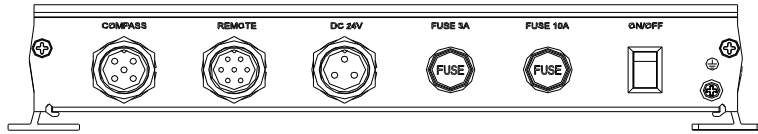
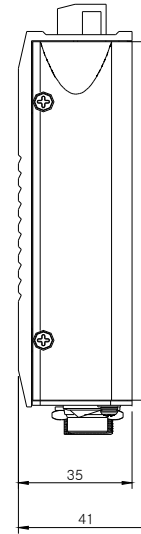
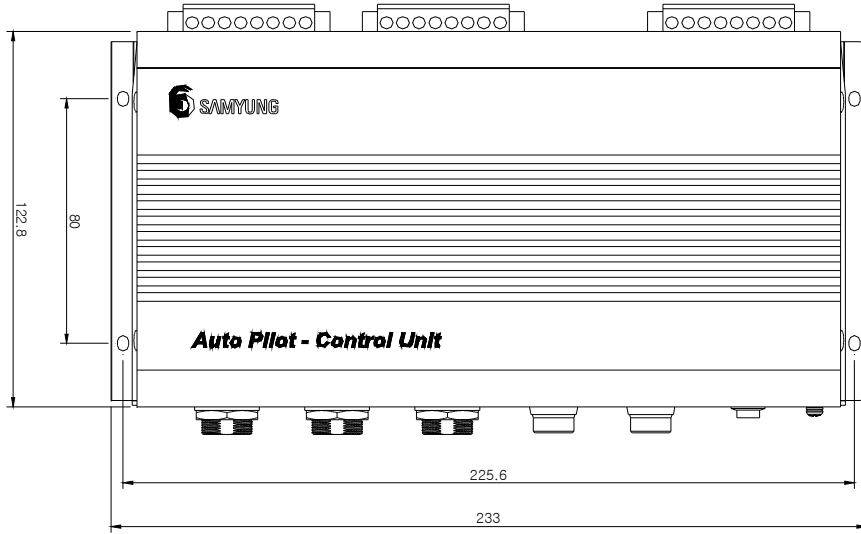
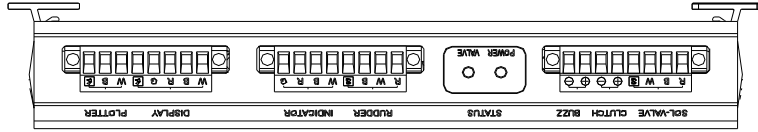

Original Drawing	Adoption Item
Ref. Drawing	Stock No.

Substitute	No.	Part Name	Q'ty	PART No.	Remark
List of component					
General Tolerance	Date	05/14/2008			
Decimal	Angle	Fraction			
±0.2	±1.0°	±1/5			
Material	Department	R&D			
Heat treatment	Approved	W.K. CHOI			
Finish	Checked	B.H. KANG			
	Designed	B.H. KANG			
Q'ty	1 EA/SET		Size		
Scale 1:1	Unit	mm	Wt	kg	
			A1		
			TITLE		
			SAMYUNG ENC		
			SAS-70C		
			DWG No. E00-9000-01		
			1 of 1		

E00-9000-02

Revision History					
No.	Loc.	Description	Modifier	Approval	Date

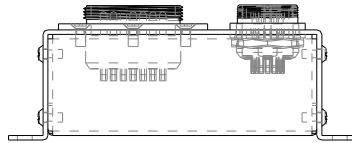
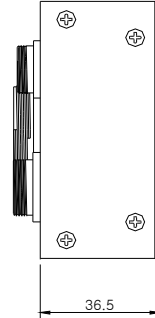
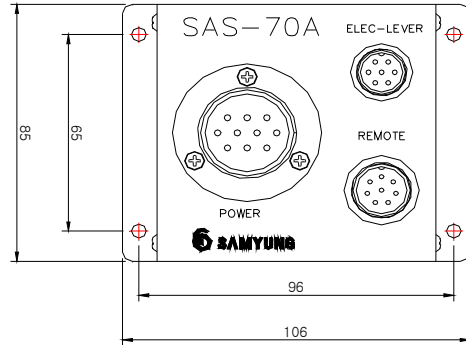

Original Drawing	General Tolerance		Date		 SAMYUNG ENC
	Decimal	Angle	Fraction	09/19/2007	
	±0.3	±1.0°	±1/5		
	Material		Department		TITLE SAS-70A
	SAS-70A		R&D		
	Heat treatment		Approved W.K. CHOI Checked B.H. KANG Designed B.H. KANG		
Ref. Drawing	Adoption Item		Q'ty		Size A2
Part No.	Stock No.		1 EA/SET		
	Finish		Scale 1:1 Unit mm Wt kg		
					DWG No. E00-9000-02 1 of 1

Chapter 8. Warranty

Thank you for your purchasing of Auto Pilot manufactured by Samyung ENC. This instruction manual shows how to install for this system and correct method for installation and any cautions. I would like to request you to keep this manual book on a safe place to avoid loss or lost. Please provide this manual book to the authorized person when you sell or provide the unit to other ones.

The period of warranty is for 1 year from purchasing date as a free of charge.

However, the unit will be repaired as a condition out of warranty when it was damaged by inappropriate usage or non-authorized repair by users.

HQ for After-Sales-Service	
ADDRESS	65-20, Namhangdong 2, Youndogu, Busan, Korea
DEPARTMENT	SAMYUNG ENC. CO. LTD. (A/S CENTER)
CONTACT	TELEPHONE : 00 82 51-416-5516
	F A X : 00 82 51-406-5515
We would like to request you tel, fax, name of item, serial number, working status in A/S request for more prompt reaction	

Regional After-Sales-Service	
P . I . C	
CONTACT	TELEPHONE :
	MOBIL :
Keep contact point of person in charge when you purchase goods	